

Technical Documentation



Intelligent Compact Drive
Pulse/direction stepper motor

IcIA IDS

Document: 0098 441 113 191

Edition: V1.03, 05.2005

Berger Lahr GmbH & Co. KG
Breslauer Str. 7
D-77933 Lahr

Important information

The drive systems described here are products for general use that conform to the state of the art in technology and are designed to prevent any dangers. However, drives and drive controllers that are not specifically designed for safety functions are not approved for applications where the functioning of the drive could endanger persons. The possibility of unexpected or unbraked movements can never be totally excluded without additional safety equipment. For this reason personnel must never be in the danger zone of the drives unless additional suitable safety equipment prevents any personal danger. This applies to operation of the machine during production and also to all service and maintenance work on drives and the machine. The machine design must ensure personal safety. Suitable measures for prevention of property damage are also required.

For more information see the chapter on safety.

Not all product types are available in all countries.

Please see the current catalogue for the availability of products.

We reserve the right to make technical changes.

All information refers to specifications and not to assured properties.

Most product designations are registered trademarks of their proprietors, even when not specifically noted.

Table of Contents

Important information	-2
Table of Contents	-3
Writing conventions and symbols	-7
1 Introduction	
1.1 Unit overview	1-2
1.2 Components and interfaces	1-3
1.2.1 Components	1-3
1.2.2 Interfaces	1-4
1.3 Documentation and literature references	1-4
1.4 Directives and standards	1-5
1.5 Declaration of conformity	1-7
1.6 TÜV certificate for functional safety	1-8
2 Safety	
2.1 Qualification of personnel	2-1
2.2 Intended use	2-1
2.3 Hazard categories	2-2
2.4 General safety instructions	2-2
2.5 Safety functions	2-2
2.6 Monitoring functions	2-3
3 Technical Data	
3.1 Environmental conditions	3-1
3.2 Electrical Data	3-2
3.3 Safety functions	3-2
3.4 UL 508C approval	3-2
3.5 Additional data	3-2
4 Basics	
4.1 Safety functions	4-1
5 Engineering	
5.1 External power supply units	5-1
5.1.1 Supply voltage	5-1
5.1.2 Signal power supply	5-2
5.2 Ground design	5-2

5.3	"Safe Standstill" safety function	5-3
5.3.1	Definitions	5-3
5.3.2	Function	5-3
5.3.3	Requirements for safe application	5-4
5.3.4	Application examples	5-5
6	Installation	
6.1	General safety instructions	6-1
6.2	Electromagnetic compatibility, EMC	6-1
6.3	Mechanical installation	6-2
6.4	Electrical installation	6-4
6.4.1	Overview of all connections	6-6
6.4.2	Input and output signals	6-6
6.4.3	Setting DIP switches	6-7
6.4.4	Connection with cable bushing	6-10
6.4.5	Power supply connection VDC	6-13
6.4.6	Connection of multifunction interface	6-15
6.4.7	24V signal interface connection	6-18
6.4.8	Safety function connection "Safe Standstill"	6-19
6.5	Checking wiring	6-21
7	Commissioning	
7.1	General safety instructions	7-1
7.2	Preparing for commissioning	7-3
7.3	Running commissioning	7-3
7.3.1	Testing safety functions	7-4
7.3.2	Check function of limit switches	7-4
7.3.3	Running test movement	7-5
7.3.4	Optimising travel behaviour of the motor	7-5
8	Operation	
8.1	Basics	8-1
8.1.1	Overview	8-1
8.1.2	Overview of motor phase current	8-1
8.2	Functions	8-2
8.2.1	Input DIR/A and PULSE/B	8-2
8.2.2	Input ENABLE	8-2
8.2.3	Input GATE	8-3
8.2.4	Input STEP2_INV	8-4
8.2.5	Input PWM	8-4
8.2.6	Output ACTIVE	8-4
8.2.7	Output FAULT	8-5
8.2.8	Output INDEXPULSE	8-5
9	Diagnostics and troubleshooting	
9.1	Error display and troubleshooting	9-1

9.1.1	Operation and error display	9-1
9.1.2	Reset error message	9-2
9.1.3	Error classes and error response	9-2
9.1.4	Causes of errors and troubleshooting.	9-2
9.1.5	Troubleshooting malfunctions in movement mode	9-3

10 Accessories and spare parts

10.1	Documentation	10-1
10.2	Accessories.	10-1

11 Service, maintenance and disposal

11.1	Service address	11-1
11.2	Maintenance	11-1
11.2.1	Operational duration of safety function.	11-1
11.3	Replacing units	11-3
11.4	Shipping, storage, disposal	11-3

12 Glossary

12.1	Terms and Abbreviations.	12-1
12.2	Product name	12-2

13 Index

Writing conventions and symbols

Work steps

If work steps must be carried out in sequence, they are shown as follows:

- Special prerequisites for the following work steps
- ▶ Step 1
- ◁ Important response to this work step
- ▶ Step 2

If a response to a work step is specified, this will inform you that the step has been carried out correctly.

Unless otherwise stated, the individual instruction steps must be carried in the given sequence.

Lists

Lists can be sorted alphanumerically or by priority. Lists are structured as follows:

- Point 1
- Point 2
 - Subpoint to 2
 - Subpoint to 2
- Point 3

Making work easier



Information on making work easier can be found at this symbol:

*This offers supplementary information on making work easier.
See the chapter on safety for an explanation of the safety instructions.*

Parameters

Parameters are shown as follows:

Group.Name Index:Subindex

1 Introduction

The IcIA IDS Intelligent Compact Drives consist of a stepper motor and integrated electronics. Control electronics and power amplifier are integrated in the housing with a pulse/direction interface and motor. If the motor has a holding brake this is also integrated.

The Intelligent Compact Drives IcIA IDS are part of the "IcIA Intelligent Compact Drive" range of products.

Drive The "Intelligent Compact Drive" moves the stepper motor as specified by a setpoint input. The setpoint signal is generated by a positioning or NC controller and fed to the multifunction interface as a pulse signal.

The resolution can be adjusted by the number of steps.

Safety function The integrated safety function "Safe Standstill" enables a stop of category 0 or 1 as per EN60204-1 without external power contactors. The supply voltage must not be interrupted. This reduces the system costs and response times.

The "Safe Standstill" safety function is available from unit revision RS10 (see type plate).

1.1 Unit overview

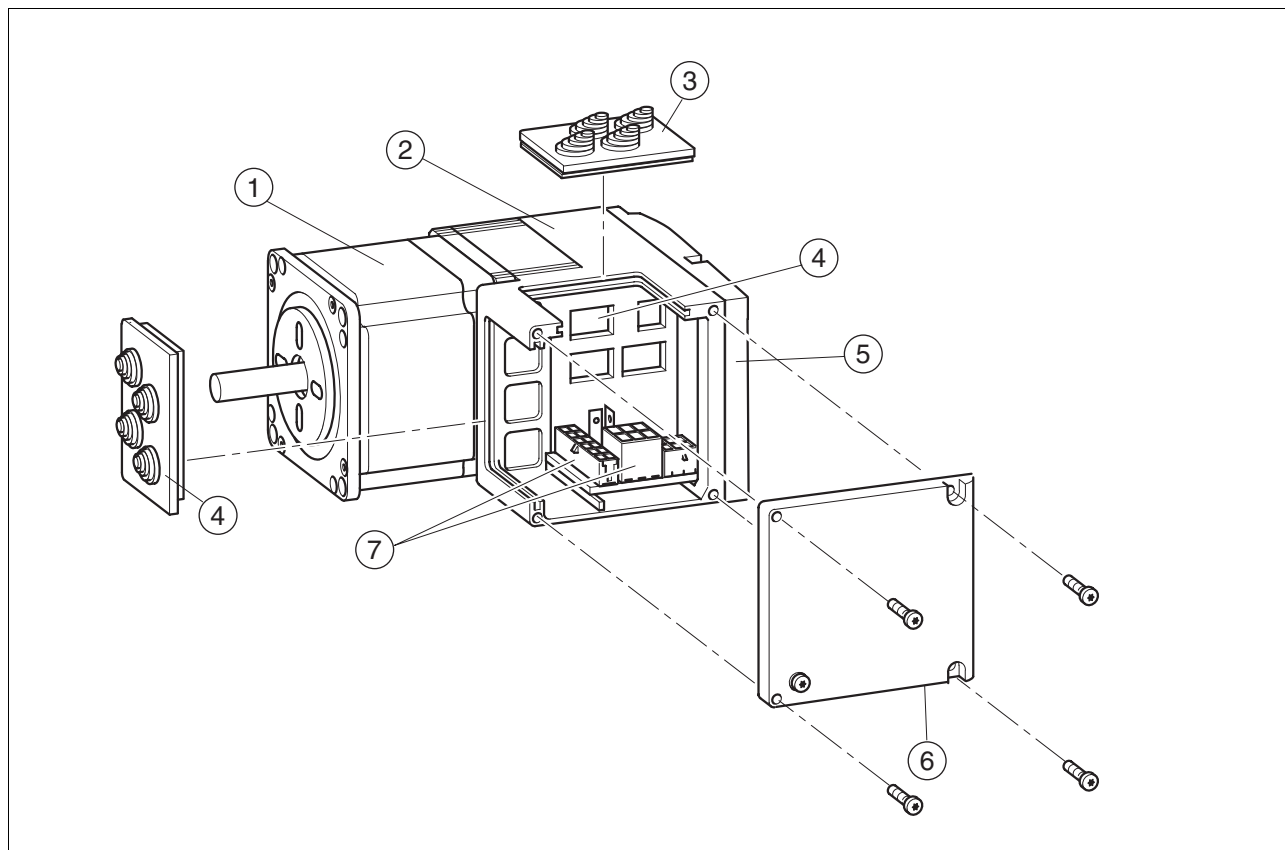

Figure 1.1 Components of the drive

- (1) Three-phase stepper motor
- (2) Electronics housing
- (3) Plug-in unit cable bushing (accessory)
- (4) Switches for making settings
- (5) Electronics cover, must not be removed
- (6) Plug cover, to be removed on installation
- (7) Electrical terminals

1.2 Components and interfaces

1.2.1 Components

Motor Six types of motor are available (maximum torque in parentheses):

- IDS61 (45 Ncm)
- IDS62 (90 Ncm)
- IDS63 (150 Ncm)
- IDS91 (200 Ncm)
- IDS92 (400 Ncm)
- IDS93 (600 Ncm)

gear The motor can be operated with a planetary gearbox (PLE).

3 gear ratios are available:

- single-stage step-down 3:1
- single-stage step-down 5:1
- single-stage step-down 8:1

Electronics The electronic system comprises control electronics and power amplifier. They have a common power supply and are not electrically isolated.

The drive system can be actuated by external reference signals via the multifunction interface.

There are also four different 24V signals available. The function of the inputs and outputs can be set with DIP switches.

Holding brake The drive (IDS9x only) can be optionally fitted with an integrated holding brake. The holding brake is controlled by the drive.

1.2.2 Interfaces

Standard available interfaces:

VDC supply voltage

Function:

- Power supply of control electronics and power amplifier



The earth terminals of all interfaces are electrically connected. For more information see chapter 5.2 "Ground design". Information on reverse polarity protection can also be found there.

Multifunction interface

This interface uses one of the following signal levels depending on the unit design:

- 24V signals optically decoupled (PD1)
- 5V signals optically decoupled (PD2)
- 5V differential signals without electrical isolation (PD3)

The reference pulses are fed in through two of the inputs, either as pulse/direction signals or as AB signals. The other inputs have the functions "power amplifier enable / pulse blocking" and "step size switching / PWM motor current control".

24-V signal interface

Two inputs and two outputs are available. The inputs are used for "step size adjustment" and "power amplifier activation / pulse blocking". The outputs have the functions "power amplifier standby" and "fault output / index pulse".

If the drive does not have an internal 24V signal power supply and you want to use outputs of the 24V signal interface, an additional external 24V signal power supply is required.

Communications interface

Function:

- connection of the RS485 bus for service purposes

A PC can be connected to this interface by a RS485-RS232 converter to use the communications interface for service purposes. Then the commissioning software can be used for functions such as reading the error memory or observing the temperature.

The RS485 interface can be used for firmware updates.

1.3 Documentation and literature references

The following User's manuals are supplied with this drive system:

- **Manual**, describes the technical data, installation, commissioning and all operating modes and operating functions.
- **Fieldbus manuals**, essential description of integration of the drive system into a fieldbus.

The order numbers for these documents can be found in chapter 10 "Accessories and spare parts".

The entire documentation is also available on CD.

Additional literature

We recommend the following literature for more in-depth information:

- Ellis, George: Control System Design Guide. Academic Press

- Kuo, Benjamin; Golnaraghi, Farid: Automatic Control Systems. John Wiley & Sons

1.4 Directives and standards

The EC directives define the minimum requirements - particularly safety requirements - applicable to a product and must be complied with by all manufacturers and dealers marketing the product in the member states of the European Union (EU).

The EC directives describe the main requirements for a product. The technical details are laid down in the harmonized standards, which are published in Germany as the DIN EN standards. If there is not yet any EN standard applicable to a particular product area, existing technical standards and regulations will apply.

CE mark With the declaration of conformity and the CE mark on the product the manufacturer certifies that the product complies with the requirements of all relevant EC directives. The drive systems described here can be used anywhere in the world.

EC Machine Directive The drive systems described here are not machines as defined by the EC Machine Directive (98/37/EEC) but components for installation in machines. They do not have moving parts designed for specific purposes. However, they can be components of a machine or system.

The manufacturer must certify that the complete system conforms to the machine directive with the CE mark.

EC EMC Directive The EC Electromagnetic Compatibility Directives (89/336/EEC) applies to products that cause electromagnetic interference or whose operation may be adversely affected by electromagnetic interference.

Conformity with the EMC Directive can only be expected of our drive systems after correct installation in the machine. The information on ensuring electromagnetic compatibility given in the chapter on "Installation" must be followed to ensure that the drive system in the machine or system is EMC-compatible and that the product can legally be operated.

EC Low-Voltage Directive The EC Low Voltage Directive (73/23/EEC) is not applicable to the compact drive, because it is operated with CD current under 50 V.

Declaration of conformity The declaration of conformity certifies that the drive system complies with the specific EC directive.

Standards for safe operation EN 60204-1: Electrical equipment of machines, General requirements
EN 60529: IP degrees of protection

IEC 61508; SIL 2; Functional safety of safety-related electric, electronic and programmable electronic systems.

pr IEC 62061; SIL 2; Safety of Machines - Functional safety of electrical, electronic and programmable controllers of machines

EN 954-1: Safety of machines, Safety of components of control devices, Part 1: General design requirements

pr EN 13849-1; Safety of machines - safety-related components of controllers - Part 1: General design requirements

Standards for retention of EMC limiting values EN 61000-4-1: Measuring and test procedures, overview
EN 61800-3: Variable-speed electrical drives

1.5 Declaration of conformity

<p><u>EC Declaration of Conformity</u> <u>Year 2005</u></p>		<p>BERGER LAHR</p> <p>BERGER LAHR GmbH & Co.KG Breslauer Str. 7 D-77933 Lahr</p>
<p><input type="checkbox"/> according to EC Directive Low Voltage 73/23/EC, changed by CE Marking Directive 93/68/EC <input checked="" type="checkbox"/> according to EC Directive on Machinery 98/37/EC <input checked="" type="checkbox"/> according to EC Directive EMC 2004/108/EC</p>		
<p>We declare that the products listed below meet the requirements of the mentioned EC Directives with respect to design, construction and version distributed by us. This declaration becomes invalid with any modification on the products not authorized by us.</p>		
Designation:		Motors with integrated Control Electronics
Type:		IFA6x, IDSxx, IFSxx, IFE7x
Product number:		0x66206xxxxxx, 0x66006xxxxxx, 0x66106xxxxxx, 0x66307xxxxxx
Applied harmonized standards, especially:	pr EN ISO 13849-1:2004, Performance Level "d" EN 50178:1998 EN 61800-3:2001, second environment according to Berger Lahr EMC test conditions	
Applied national standards and technical specifications, especially:	EN 61508:2000, SIL2 UL 508C Berger Lahr EMC test conditions 200.47-01 EN Product documentation	
<p style="text-align: center;">Berger Lahr GmbH & Co. KG</p> <p>Company stamp: Postfach 11 80 · D-77901 Lahr Breslauer Str. 7 · D-77933 Lahr</p> <p>Date/ Signature: 20 May 2005 </p> <p>Name/ Department: Wolfgang Brandstätter/R & D Drive Systems</p>		

Figure 1.2 Declaration of conformity

0098 441 113 191, V1.03, 05.2005

1.6 TÜV certificate for functional safety

The certificate of the Certification Body RWTÜV Systems GmbH of Product Safety and Medical Devices is subject to approval at the moment and will be provided soon.

2 Safety

2.1 Qualification of personnel

Only technicians who are familiar with and understand the contents of this manual and the other relevant manuals are authorised to work on and with this drive system. The technicians must be able to detect potential dangers that may be caused by setting parameters, changing parameter values and generally by the mechanical, electrical and electronic equipment.

The technicians must have sufficient technical training, knowledge and experience to recognise and avoid dangers.

The technicians must be familiar with the relevant standards, regulations and safety regulations that must be observed when working on the drive system.

2.2 Intended use

The drive systems described here are products for general use that conform to the state of the art in technology and are designed to prevent any dangers. However, drives and drive controllers that are not specifically designed for safety functions are not approved for applications where the functioning of the drive could endanger persons. The possibility of unexpected or unbraked movements can never be totally excluded without additional safety equipment. For this reason personnel must never be in the danger zone of the drives unless additional suitable safety equipment prevents any personal danger. This applies to operation of the machine during production and also to all service and maintenance work on drives and the machine. The machine design must ensure personal safety. Suitable measures for prevention of property damage are also required.

In the system configuration described the drive systems must be used in industrial applications only and must have a fixed connection only.

In all cases the applicable safety regulations and the specified operating conditions, such as environmental conditions and specified technical data, must be observed.

The drive system must not be commissioned and operated until completion of installation in accordance with the EMC regulations and the specifications in this manual.

To prevent personal injury and damage to property damaged drive systems must not be installed or operated.

Changes and modifications of the drive systems are not permitted and if made all no warranty and liability will be accepted.

The drive system must be operated only with the specified wiring and approved accessories. In general, use only original accessories and spare parts.

The drive systems must not be operated in an environment subject to explosion hazard (ex area).

2.3 Hazard categories

Safety notes and general information are indicated by hazard messages in the manual. In addition there are symbols and instructions affixed to the product that warn of possible hazards and help to operate the product safely.

Depending on the seriousness of the hazard, the messages are divided into three hazard categories.



DANGER!

DANGER indicates an imminently hazardous situation, which, if not avoided, **will result** in death, serious injury, or equipment damage.



WARNING!

WARNING indicates a potentially hazardous situation, which, if not avoided, **can result** in death, serious injury, or equipment damage.



CAUTION!

CAUTION indicates a potentially hazardous situation, which, if not avoided, **can result** in injury or equipment damage.

2.4 General safety instructions



WARNING!

Danger of injury and damage to system components by loss of control!

- Observe the accident prevention regulations.
- Consideration of possible errors must also include unexpected delay and failure of signals or functions.
- Separate redundant controller paths must be provided for dangerous functions.
- Verify the effectiveness of the measures.

2.5 Safety functions

Using the safety functions integrated in this product requires careful planning. For more information see 5.3 ""Safe Standstill" safety function" on page 5-3.

2.6 Monitoring functions

The monitoring functions in the drive protect the system and reduce the risk in the event of system malfunction. The monitoring functions are not designed for personal safety. The following faults and limit values can be monitored:

Monitoring	Task	Protective function
Stall detection (only for units with index pulse)	Checks the motor movement using the index pulse	Function safety
Motor overload	Monitoring for excessively high current in the motor phases	Functional safety and device protection
Overvoltage and undervoltage	Monitoring for overvoltage and undervoltage of the power supply	Functional safety and device protection
Overtemperature	Monitoring device for overtemperature	Device protection

Table 2.1 Monitoring functions

3 Technical Data

3.1 Environmental conditions

When considering the ambient temperature a distinction is made between the permissible temperatures during operation and the permissible storage and transport temperature.

ambient operating temperature

The maximum permissible ambient air temperature during operation depends on the clearance between the units and the required output. The relevant requirements in the chapter on installation are also very important.

Ambient temperature ¹⁾	°C	0 .. 65; 50°C.. 65°C: reduced power rating: 2%/K
-----------------------------------	----	--

1) Limit values of a flange-mounted motor (i.e. steel plate 300x300x10)

Ambient climate for transport and storage

The environment during transport and storage must be dry and dust-free. The maximum oscillation and shock stress must be within the specified limits. The bearing and transport temperature must remain within the specified range.

Temperature for transportation and storage	°C	-25 .. 70
--	----	-----------

Motor temperature

Max. admissible motor temperature	°C	110
-----------------------------------	----	-----

Relative humidity

The relative humidity is allowed as follows:

Relative humidity	%	15 .. 85
-------------------	---	----------

Installation height

Installation height without reduced power rating	m above MSL	< 1000 m above sea level
--	-------------	--------------------------

Vibration and shock loading

The strength during oscillation stress on the units corresponds to EN 50178 Section 9.4.3.2 and EN 61131 Section 6.3.5.1.

Vibration strain during operation as per DIN EN 60068-2-6

Number of cycles		10
Acceleration amplitude	m/s ²	20
Frequency range	Hz	10...500

Continuous shocks as per DIN EN 60068-2-29

Number of shocks		1000
Peak acceleration	m/s ²	150

Degree of protection

Protection class according to DIN EN 60052-9-1	IP54 Gesamtgerät außer Wellendurchführung; IP41 Wellendurchführung
--	--

3.2 Electrical Data

Supply voltage

Rated voltage	V_{DC}	24 or 36
Limit values	V_{DC}	18 to 40
Ripple at rated voltage	V_{SS}	≤ 3.6
Max. power consumption IDS6x	O	3.5
Max. power consumption IDS9x	O	5
Starting current		charging current of capacitor $C=1500\mu F$
External fuse	O	≤ 16

3.3 Safety functions

Data for maintenance schedule and safety calculations

Use the following data for your maintenance schedule and safety calculations:

Service life corresponding to safety life cycle (IEC 61508)		20 years
SFF (Safe Failure Fraction) (IEC61508)		67%
Probability of a dangerous failure per hour (PFH) (IEC 61508)		$1.84 \cdot 10^{-9}$ 1/h
Response time (until shutdown of power amplifier)	ms	<50
Permitted test pulse width of upstream units	ms	≤ 1

3.4 UL 508C approval

Pollution degree

Pollution degree	Step 2
------------------	--------

Power supply

Use only power supply units that are approved for overvoltage category 3.

Wiring

Use copper wiring resistant to at least 60°C or 75°C.

3.5 Additional data

See the catalogue for additional technical data:

- "IcIA Intelligent Compact Drives"
Order no. 0059 941 201 001

4 Basics

4.1 Safety functions

Automation and safety engineering are two areas that were completely separate in the past but more recently have become more and more integrated. Planning and installation of complex automation solutions are greatly simplified by integrating safety functions. Safety-oriented functions are taken into consideration when planning automation and risks can be minimised more easily.

In general the safety engineering requirements depend on the application. The degree of the requirements is oriented to the risk and the hazard potential arising from the specific application.

Working with IEC61508

IEC61508 standard

The IEC61508 standard "Functional safety of safety-related electric, electronic and programmable electronic systems" covers the relevant safety-relevant function. This means that it is not only one single component but always a complete function chain (e.g. from the sensor through the logical processing unit to the actuator) that is considered as one single unit. The function chain must meet the requirements of the specific safety level as a whole. The standard establishes a basic standard that is virtually application-independent. Systems and components that can be used in various applications for safety tasks with comparable risk can be developed in this base.

SIL, Safety Integrity Level

The comparable risk is defined by the maximum achievable safety level SIL, which can be at level 1 to level 4 (maximum safety). This is based on an assessment of the hazard potential derived from the hazard and risk analysis. This is used to decide whether the relevant function chain requires a safety function and which hazard potential it must cover.

PFH, Probability of a dangerous failure per hour

To maintain the safety function the IEC61508 standard, depending on the required SIL, requires staged fault-control and fault-prevention measures. All components of a safety function must be subjected to a probability analysis to assess the effectiveness of the fault-control measures that were taken. This assessment determines the dangerous probability of failure PFH (probability of a dangerous failure per hour) for protective systems. This is the probability per hour that a protective system fails in a hazardous manner and the protective function cannot be correctly executed. The PFH must not exceed the values calculated for the complete protective system depending on the SIL. The individual PFH of a chain must be calculated together, the total of the PFH must not exceed the maximum value specified in the standard.

SIL	PFH at high requirement rate or continuous requirement
4	$\geq 10^{-9}$ to $< 10^{-8}$
3	$\geq 10^{-8}$ to $< 10^{-7}$
2	$\geq 10^{-7}$ to $< 10^{-6}$
1	$\geq 10^{-6}$ to $< 10^{-5}$

HFT and SFF The standard also requires a specific hardware fault tolerance HFT for the safety system depending on the SIL in connection with a specific proportion of safe failures SFF (safe failure fraction). The hardware fault tolerance is the property of a system that enables it to execute the desired safety function in spite of the presence of one or more hardware faults. The SFF of a system is defined as the ratio of the rate of safe failures to the total failure rate of the system. Under IEC61508 the maximum achievable SIL of a system is determined by the hardware fault tolerance HFT and the safe failure fraction SFF of the system.

SFF	HFT type A subsystem		
	0	1	2
<60%	SIL1	SIL2	SIL3
60%- <90%	SIL2	SIL3	SIL4
90%- < 99%	SIL3	SIL4	SIL4
≥ 99%	SIL3	SIL4	SIL4

Fault-prevention measures Systematic faults in the specifications, in the hardware and the software, usage faults and maintenance faults of the safety system must be avoided as much as possible. IEC61508 specifies a series of fault-prevention measures that must be implemented depending on the required SIL. The fault-prevention measures must accompany the complete life cycle of the safety system, i.e. from design to decommissioning of the system.

5 Engineering

This chapter contains basic information on options for use of the product, which are essential for the engineering.

5.1 External power supply units



DANGER!

Electric shock from incorrect power supply unit.

The +24V_{DC} and V_{DC} supply voltages are connected with many exposed signals in the drive system.

- Use a power supply unit that meets the requirements for PELV (Protective Extra Low Voltage)
- Connect the negative output of the power supply unit to PE.

5.1.1 Supply voltage

General

The power supply unit must be designed to meet the power requirements of the drive. The power consumption can be found in the technical data.

The actual power requirement is often significantly lower, because the maximum possible motor torque is not required to ensure safe operation of a system.

When designing the system note that during the motor acceleration phase the drive may use a higher current compared to constant movement.

Transformer power supply units with sufficient output capacity (e.g. 10,000 µF) should be used. They are generally available as 24V_{DC} power supplies.

For example, a standard 24V_{AC} transformer can be used to maintain up to 36V_{DC} depending on rectification and filtering.

Reverse polarity protection

If the polarity of the V_{DC} supply voltage is reversed, the drive shows a short circuit. The drive is short-circuit-resistant up to an effective short-circuit current of maximum 15A. If the power is supplied by a transformer power unit several hundred amperes may flow momentarily in the event of polarity reversal; the drive is designed for this and will not be damaged.

Fuses: a circuit-breaker (16A, B-characteristic) or a blade-type fuse (FKS, max. 15A) or a fusible link (5 x 20mm, 10A slow-blow).

Wire cross-sections of 0.75 mm² to max. 4.0 mm² (with very long cables) can be used for the V_{DC} supply voltage. The standard is 1.5 mm².

Energy recovery

Note the following if the drive is operated highly dynamically or with large external mass moments of inertia:

During deceleration (depending on the external mass moment of inertia and the set deceleration ramp) or in braking mode the drive can generate power. The external power supply unit must be able to accept the

generated energy. If it cannot (e.g. output capacitor in power supply unit too small), an overvoltage condition may occur on the power line. The drive detects the overvoltage and triggers an overvoltage error from about 47V. Overvoltages resulting from energy recovery are limited to 50V by the drive.

If energy recovery is expected in an application, the power supply unit must be appropriately designed. In many cases the excess voltage can be reduced during energy recovery by switching higher capacities. Pay attention to the higher load currents when switching on the power supply unit.

Because of these considerations only chopper-type power supplies that have a sufficiently high output capacity can be recommended.

Transformers with appropriate rectifier circuits are available on the market and with their high output capacity they provide good results.



CAUTION!

Destruction of system components by loss of control over the controller caused by overvoltage at V_{DC} !

During energy recovery while braking the drive the V_{DC} supply voltage may increase up to 50V. Components not designed for this voltage may be destroyed or they may malfunction.

- Use a separate power supply unit for the V_{DC} supply voltage of the drive.
- Do not use the V_{DC} supply voltage for other consumers (such as limit switches).
- Use only power supply units that will not be damaged by energy recovery.

5.1.2 Signal power supply

External 24V signal power supply

In the case of drives without internal 24V signal power supply the V_{DC} supply voltage must not be bridged at +24V V_{DC} . A separate power supply unit must be used for the 24V signal power supply.

Internal 24V signal power supply

A constant 24V signal power supply is available for the sensor power supply on drives with internal 24V signal power supply.

It must not be connected in parallel with the internal 24V signal power supply of a different drive.

5.2 Ground design

The electrical bonding of all interfaces are electrically connected, including the earth for the V_{DC} supply voltage (the module interfaces with electrical isolation such as PD1 and PD2 are exceptions).

The following points must be considered when wiring the drives in a system:

- the voltage drop on the V_{DC} power supply lines must be kept as low as possible (less than 1 V). At higher frame potential differences

between different drives the communications and control signals may be affected in some cases.

- at greater distances between the system components decentralised power supply units for the VDC supply voltage close to the drives are the better alternative. However, the individual power supply units must be bonded with largest possible line cross-section.
- in the case of drives with internal 24V signal power supply they must not be connected in parallel with the internal 24V signal power supply of a different drive.
- if the master controller (e.g. PLC, IPC etc.) does not have electrically isolated outputs for the drives, it is necessary to ensure that the current for the VDC power supply has no path back to the power supply unit via the master controller. The master controller earth must therefore be connected to the VDC power supply earth at one point only. This is generally the case in the switch cabinet. The earth contacts of the various signal connectors in the compact drive are therefore not connected; there is already a connection via the VDC power supply earth.
- if the controller has, for example, an electrically isolated RS485 interface for communication with the drives, the electrically isolated earth of this interface should be connected with the corresponding signal earth of the first drive. This connection is not made in the other drives on the bus. The same applies for an electrically isolated CAN connection.

Equipotential bonding conductors

The shields are connected at both ends for fault protection. Potential differences can result in excessive currents on the shield and must be prevented by equipotential bonding conductor cables.

If lines over 100 m are approved, the following applies: up to 200 m length a cable cross section of 16 mm² is sufficient, for greater lengths a cable cross section of 20 mm² is required.

5.3 "Safe Standstill" safety function

For some general information on the application of IEC 61508 see page 4-1.

5.3.1 Definitions

Safe Standstill The Safe Standstill safely shuts down the motor torque. The supply voltage must not be interrupted. There is no monitoring at standstill.

Category 0 stop (EN60204-1) Stopping by immediate removal of power to the machine actuators (i.e. an uncontrolled stop).

Category 1 stop (EN60204-1) A controlled stop with power available to the machine actuators to achieve the stop and then removal of power when the stop is achieved;

5.3.2 Function

The "Safe Standstill" safety function integrated into the product can be used to implement the control function "Emergency Stop" (EN 60204-1) for Stop Category 0 and Stop Category 1. In addition, this safety function prevents the drive from restarting unexpectedly.

The following safety levels are implemented in accordance with the standards for functional safety:

- IEC 61508; SIL 2; Functional safety of safety-related electric, electronic and programmable electronic systems.
- pr IEC 62061; SIL 2; Safety of Machines - Functional safety of electrical, electronic and programmable controllers of machines
- EN 954-1: Safety of machines, Safety of components of control devices, Part 1: General design requirements
- pr EN 13849-1; Safety of machines - safety-related components of controllers - Part 1: General design requirements

Function The Safe Standstill safety function can be triggered with the two redundant inputs `SAFE_DISABLE_A` and `SAFE_DISABLE_B`. The circuits of the two inputs must be separate from each other to retain the two channels. The switching process must occur simultaneously for both inputs (skew <1s).
The power amplifier is without power and an error message is sent, even if one of the two inputs is shut down. Then the motor cannot generate torque and runs down without braking. A restart is only possible after resetting the error message.

5.3.3 Requirements for safe application



WARNING!

Danger of injury by incorrect usage!

Incorrect usage may cause a safety hazard by loss of the safety function.

- Observe the requirements for the safety function.

Stop of category 0 In a stop of category 0 the drive runs down uncontrolled. If access to the machine while it is running down is a hazard (result of hazard and risk analysis), suitable measures must be taken.

Stop of category 1 For stop of category 1 a controlled stop can be executed via the profile generator of the master controller. The standstill is not monitored by the drive system and is not guaranteed if power fails or in the event of an error. The final shutdown is ensured by shutting down the inputs `SAFE_DISABLE_A` and `SAFE_DISABLE_B`. This is generally controlled by a standard EMERGENCY STOP module with safe time delay.

Vertical axes, external forces If external forces act on the drive (vertical axis) and an unwanted movement, for example caused by gravity, could cause a hazard, the drive must not be operated without additional measures for drop protection corresponding to the required safety.

Prevention of unexpected restart To prevent unexpected restart after restoration of power (e.g. after power failure), the CN6 bridge must be removed. This causes the `ENABLE` or `GATE` signal input to respond edge-controlled and no longer static. Note that a higher level controller (profile generator) must also not trigger a dangerous restart.

Protected line layout If short circuits and cross connections are possible with the lines for the signals `SAFE_DISABLE_A` and `SAFE_DISABLE_B` and this cannot be detected by upstream devices, a protected layout is required.

A protected layout can be achieved as follows:

- Allocation of signals to different cables. Apart from SAFE_DISABLE_A and SAFE_DISABLE_B only wires with voltages corresponding to PELV are permitted to be run on these cables.
- Use of a shielded cable. The earthed shield protects the signals from outside voltages.

If there are multiple wires in the cable, the signals SAFE_DISABLE_A and SAFE_DISABLE_B are kept separate from these wires by the earthed shield.

Data for maintenance schedule and safety calculations

Use the following data for your maintenance schedule and safety calculations:

Service life corresponding to safety life cycle (IEC 61508)	20 years
SFF (Safe Failure Fraction) (IEC61508)	67%
Probability of a dangerous failure per hour (PFH) (IEC 61508)	$1.84 \cdot 10^{-9}$ 1/h
Response time (until shutdown of power amplifier)	ms <50
Permitted test pulse width of upstream units	ms ≤1

Hazard and risk analysis

As a system manufacturer you must conduct a hazard and risk analysis (e.g. as per EN 1050) of the system. The results should be taken into account when using the "Safe Standstill" safety function.

The circuit resulting from the analysis may deviate from the following application examples. Additional safety components may be required. The results of the hazard and risk analysis always have priority.

5.3.4 Application examples

Example: category 0 stop Circuit without EMERGENCY STOP module, Stop category 0.

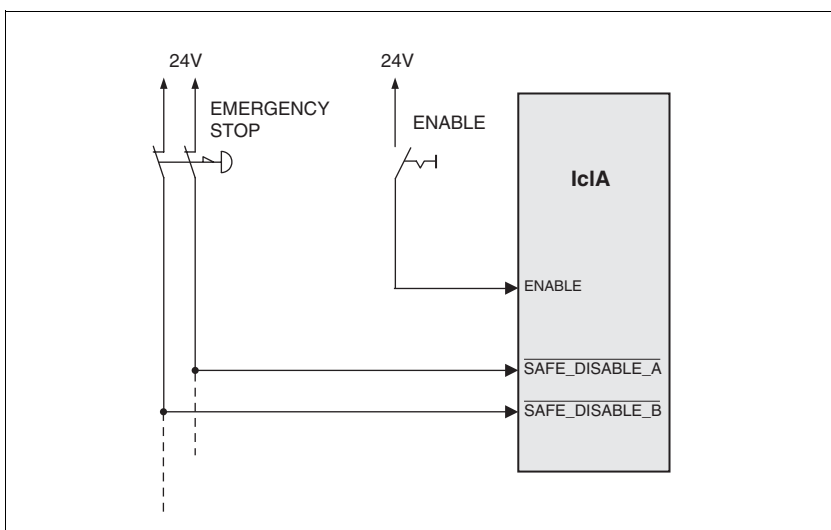

Figure 5.1 Example: category 0 stop

Please note:

- When the EMERGENCY STOP switch is tripped it initiates a stop of category 0

Example: category 1 stop Circuit with EMERGENCY STOP module, Stop category 1,

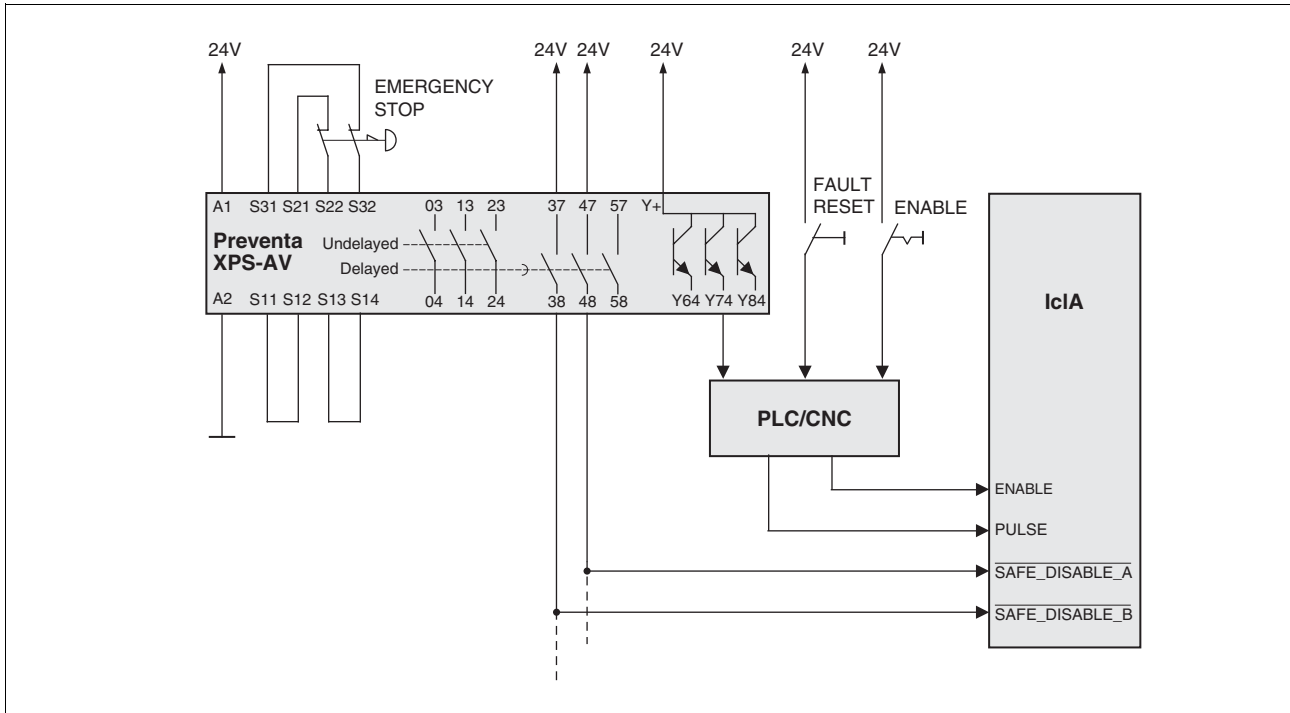

Figure 5.2 Example: category 1 stop

Please note:

- The master controller (profile generator) receives an undelayed stop signal from the EMERGENCY STOP module must bring the drive to a controlled standstill.
- The $\overline{\text{SAFE_DISABLE_A}}$ and $\overline{\text{SAFE_DISABLE_B}}$ inputs are switched off after the delay time specified by the EMERGENCY STOP module. If the drive has not yet stopped at this time, it runs down without control (uncontrolled standstill).
- The specified minimum current and the allowed maximum current of the relay must be maintained in the circuitry of the relay outputs at the EMERGENCY STOP module.

6 Installation

6.1 General safety instructions



CAUTION!

Risk of injury when removing circuit board plugs

- When removing it make sure that the connectors are unlocked.
 - Supply voltage ∇ DC: unlock by pulling at the connector shell
 - Miscellaneous: unlock by pressing the locking lever
- Always hold the connector to remove it (not the cable).

6.2 Electromagnetic compatibility, EMC



WARNING!

Interference with signals and devices may cause injury

Distorted signals can cause unexpected device responses.

- Install the wiring in accordance with the EMC requirements.
- Check compliance with the EMC requirements, particularly in an environment subject to strong interference.

The drive and the system are subject to electromagnetic interference. If suitable precautions are not taken, the interference will affect the signals from the control lines and system parts and adversely affect the operating reliability of the system.

Before operation the electromagnetic compatibility of the system must be checked and assured. The drive system conforms to the requirements of the EC directives on EMC immunity to interference under DIN EN 61800-3: 2001-02 for the second environment where the following actions are taken into account during installation.

To maintain the limit values for the EMC interference resistance and interference radiation the drive must be earthed. It can be grounded from the motor flange or the electronics housing. This is generally done by bolting the motor to an electrically conductive and earthed machine component for sufficient earthing of the drive.

EMC measures	Effect
Cable as short as possible. No ground loops.	Prevent capacitive and inductive fault interference
The electronics case is electrically connected to the motor. Earthing drive through the motor flange. If this is not possible, provide additional earth wire connected to the plug cover lid or with a cable clip to the flange. Note that in this case the drive will not be earthed when the cover is removed.	Reduced emissions, Increased resistance to interference
Earth shields on digital signal lines over a wide area at both ends or via conductive plug housing.	Preventing interference on control cables, reduction of emissions
Connect large surface areas of cable shields, use cable clamps and tapes	Reduction of emissions.

Table 6.1 EMC measures

The following cables must be shielded:

- Multifunction interface
- "Safe Standstill" safety function, note the requests in the chapter 5.3.3 "Requirements for safe application"

The following cables can be left unshielded:

- Supply voltage V_{DC}
- 24-V signal interface

Equipotential bonding conductors

The shields are connected at both ends for fault protection. Potential differences can result in excessive currents on the shield and must be prevented by equipotential bonding conductor cables.

If lines over 100 m are approved, the following applies: up to 200 m length a cable cross section of 16 mm² is sufficient, for greater lengths a cable cross section of 20 mm² is required.

6.3 Mechanical installation



CAUTION!

Hot surfaces can cause burns and damage to system components!

The drive temperature can exceed 100°C in some conditions.

- Avoid contact with the hot drive.
- Do not place combustible or heat-sensitive components in immediate vicinity.
- Follow the actions described for heat dissipation.
- Check the temperature of the drive during the test run.

**CAUTION!****Damage of drive and loss of control!**

A shock or strong pressure against the motor shaft may destroy the drive.

- Protect the shaft when working on the drive and during transport.
- Avoid shocks to the shaft during installation.
- Do not press any parts against the shaft. Any parts that must be attached to the shaft should be fastened by adhesives, clamping, shrinkage or screws.

**WARNING!****Danger of injury and damage to system components by unbraked motor!**

Loss of power or faults that result in switching off the power amplifier mean that the motor is no longer actively braked and may run against a mechanical stop at high speed.

- Check the mechanical conditions.
- If necessary, use an absorbent mechanical stop or a suitable brake.

**WARNING!****Wear or high temperature will cause loss of braking power.**

Incorrect use of the holding brake causes accelerated wear and loss of braking power. Heat reduces the holding torque.

- Do not use the brake as a service brake.
- At operating temperatures over 80°C do not exceed a maximum of 50% of the specified holding torque when using the brake.

**WARNING!****Violations and system damage by falling loads during start-up.**

When the brake is released on stepping motor drives with external forces (vertical axes), the load may fall if the friction is low.

- Restrict the load in these applications to a maximum of 25% of the static holding torque.



When installing the drive in less accessible positions, it may be useful to carry out the electrical installation first and then install the fully wired drive.

<i>Heat dissipation</i>	<p>The drive may become very hot, e.g. in the case of incorrect arrangement of multiple drives. The surface temperature of the motor must not exceed 110 °C in continuous operation.</p> <ul style="list-style-type: none">• Make sure that the maximum temperature is not exceeded by maintaining sufficient distance or good ventilation for every single drive.• If the drive is operated to the limits of its performance, adequate heat dissipation via the motor flange is essential
<i>Fixing</i>	<p>The motor must be fixed with four M5 bolts. Use washers with smaller bolts. Install the drive on a flat horizontal surface to prevent transmission of mechanical tension to the housing.</p>
<i>Installation clearances</i>	<p>No minimum clearances are required for installation. However, note that the drive can become very hot.</p> <p>Note the bending radii of the cables used.</p>
<i>Ambient conditions</i>	<p>Note the permissible environmental conditions.</p>

6.4 Electrical installation



WARNING!

Danger of injury and damage to system components by loss of degree of protection

Foreign bodies, deposits or humidity can cause unexpected device responses.

- Prevent any foreign bodies from entering the terminal unit.
- Do not remove the electronic case cover. Only remove the plug cover.
- Check that seals and cable glands are correctly seated.



WARNING!

Danger of injury by loss of safety function!

The safety function may fail because of conductive foreign bodies, liquids or dust. The "Safe Stop" safety function must only be used when the degree of protection IP54 is assured.

- Ensure degree of protection IP54.

**CAUTION!****Destruction of unit components and loss of control monitoring!**

Excessive currents can be created at the signal connections if the negative connection to the controller supply voltage is interrupted.

- Do not interrupt the negative connection between power supply unit and load with a fuse or switch
- Check for correct connection before switching on.
- Never connect the controller supply voltage or change its wiring while there is supply voltage present.



The chapter on engineering contains basic information that you should know before starting the installation.



The drive has DIP switches in the connector shell. Set the DIP switches before connecting the cables, because after connection they are difficult to access.

6.4.1 Overview of all connections

Overview of printed circuit board plug connectors

The following figure shows the pin assignment of the interfaces with the connector shell cover open.

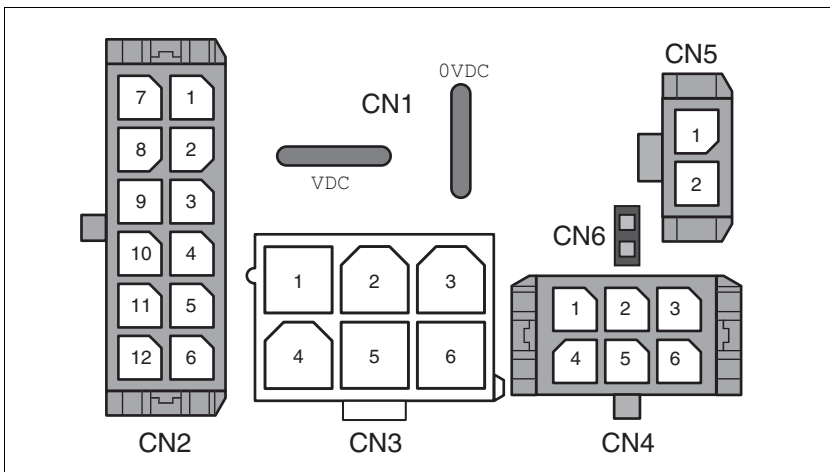

Figure 6.1 Overview of all connections

Terminal	Assignments
CN1	Supply voltage VDC
CN2	Multifunction interface
CN3	Service interface
CN4	24-V signal interface
CN5	Interface for "Safe Standstill" safety function
CN6	Bridge for disabling "Safe Standstill" safety function

6.4.2 Input and output signals

The various functions of the drive are available at two different interfaces. The inputs and outputs of the two different interfaces are distinguished by the signal level.

Overview

Function	Connection CN2	Connection CN4	I/O
PULSE/DIR	CN2.6/12 / CN2.5/11	-	I
A / B	CN2.5/11 / CN2.6/12	-	I
ENABLE	CN2.4/10	CN4.2	I
GATE	CN2.4/10	CN4.2	I
STEP2_INV	CN2.3/9	CN4.5	I
PWM	CN2.3/9	-	I
ACTIVE	CN2.2/8	CN4.6	O
FAULT	-	CN4.2	O
INDEXPULSE	-	CN4.2	O

6.4.3 Setting DIP switches

The diagram below shows an overview of the available DIP and rotary switches. The switches are shown as viewed with the plug housing open.

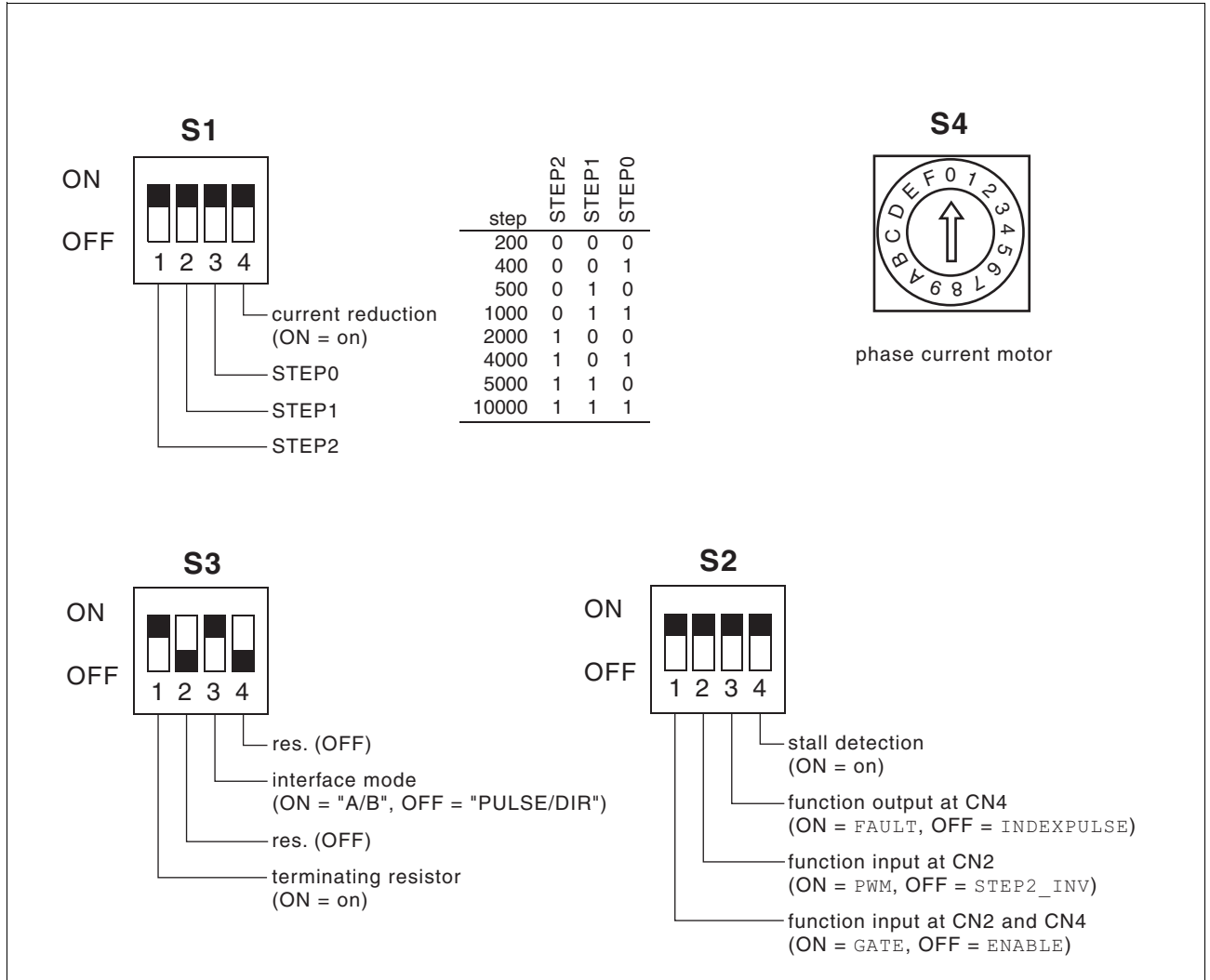

Figure 6.2 DIP switches

6.4.3.1 Switch S1

Setting number of steps

The resolution of the drive can be adjusted by the number of steps.

Example: at a number of steps of 1000 the drive runs exactly one complete motor revolution at 1000 pulses.

At a pulse frequency of 1 kHz this yields a speed of 1 rev/s = 60 rpm

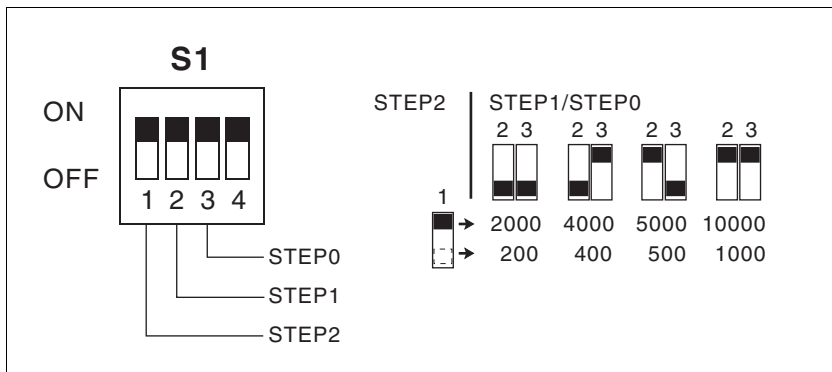

Figure 6.3 Setting number of steps

- Set the number of steps with DIP switches 1.1...1.3. The number of steps that was selected with "STEP0" and "STEP1" can be increased by 10 times the value with "STEP2".

The "STEP2" setting can be inverted via the input signal "STEP2_INV" of the multifunction interface of the 24V signal interface.

Setting current reduction

If the full holding torque is not required at standstill, the function "current reduction" can be used to reduce the holding torque.

Advantage: Motor and electrics heat up less and the efficiency is improved.

Switch setting S1.4	Meaning
ON	Current reduction enabled
OFF	Current reduction disabled

The motor phase current is reduced to approximately 70% of the set current 100 ms after receiving the last pulse slope.



WARNING!

Violations and system damage by falling loads at standstill.

When the current reduction is enabled, the motor torque at standstill is reduced and result dropping in the case of axes with external forces (vertical axes).

- Check whether the load rations allow operation with current reduction.
- If necessary, switch on the current reduction.

6.4.3.2 Switch S2

Setting "ENABLE/GATE" signal input

The "ENABLE/GATE" signal can have two functions:

Switch setting S2.1	Meaning
ON	"GATE" function Enable or block power amplifier
OFF	"ENABLE" function Enable or block pulse input

Setting "STEP2_INV/PWM" signal input

The "ENABLE/GATE" signal is available at the following interfaces:

- 24-V signal interface
- Multifunction interface

The "STEP2_INV/PWM" signal can have two functions:

Switch setting S2.2	Meaning
ON	"PWM" function Motor phase current control or current reset to zero by pulse widening at signal input.
OFF	"STEP2_INV" function Meaning of inverting the DIP switch 1.1 "STEP2" (increase or reduce number of steps by a factor of 10)

The "STEP2_INV/PWM" signal is available at the following interfaces:

- Multifunction interface
- STEP2_INV also at 24V signal interface

Setting "FAULT/INDEXPULSE" signal output

The "FAULT/INDEXPULSE" signal can have two functions:

Switch setting S2.3	Meaning
ON	"FAULT" function
OFF	"INDEXPULSE" function

The index pulse signal can only be switched at the "FAULT/INDEXPULSE" signal output on drives with index pulse.

The "FAULT/INDEXPULSE" signal is available at the following interfaces:

- 24V signal interface, pin 3

Set stall detection

Switch setting S2.4	Meaning
ON	Stall detection enabled
OFF	Stall detection disabled

The drive is fitted with stall detection as an option. The stall detection responds if the actual position of the axis deviates from the setpoint position by more than one revolution. The function is only available on drives with index pulse.

If the stall detection responds the power to the drive is disconnected and the signal output `FAULT` is set.

6.4.3.3 Switch S3

Setting terminating resistor

Switch setting S3.1	Meaning
ON	125Ω terminating resistor enabled
OFF	125Ω terminating resistor disabled

Setting interface mode

Switch setting S3.4	Meaning
ON	"A/B" interface mode
OFF	"PULSE/DIR" interface mode

The value of the setpoint position can be fed in at the signal interface as pulse-direction signals or AB encoder signals. The drive converts the input signals corresponding to the switch position within one motor movement.



Reserved DIP switches are reserved for future upgrades and must be set to "OFF".

6.4.3.4 Switch S4

The motor phase current is set with a rotary switch S4. A high motor phase current generates a high motor torque.

Switch position S4	Motor phase current ¹⁾
0	25
1	30
2	35
3	40
4	45
5	50
6	55
7	60
8	65
9	70
A	75
B	80
C	85
D	90
E	95
F	100

1) in percent of rated current

6.4.4 Connection with cable bushing

You can order prepared cables with connectors installed from your dealer or prepare the cables yourself.

The wiring specifications and pin assignment can be found in the chapters that describe the connections.

Preparing and fastening wiring

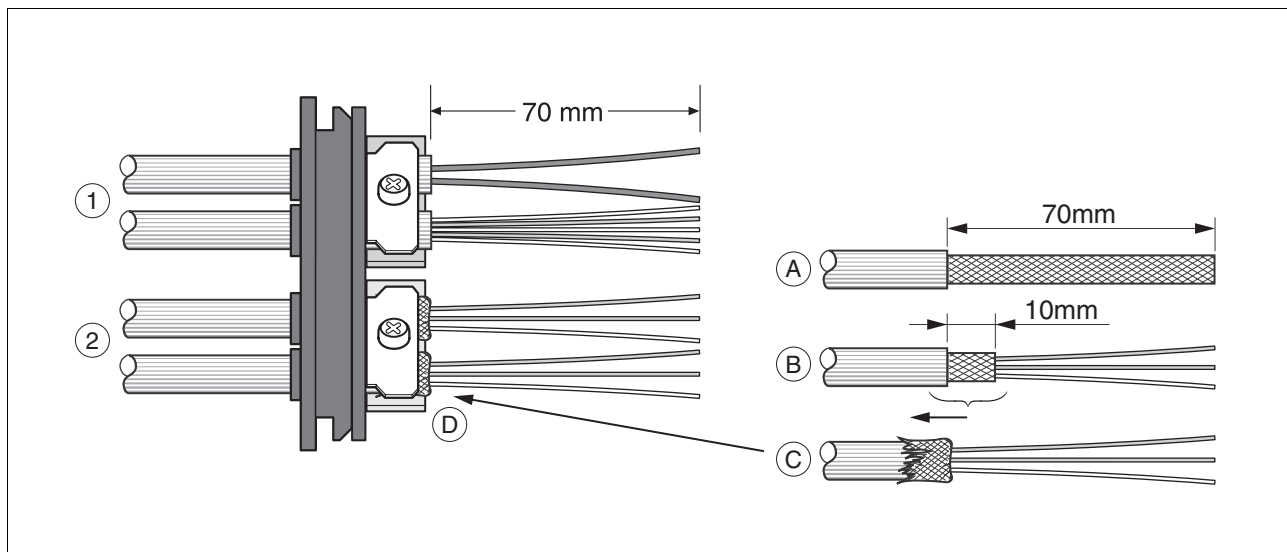

Figure 6.4 Fasten cable in bushing

- (1) unshielded cable
- (2) shielded cable

▶ Select the correct cable cross section to ensure that the drive remains sealed.

CAUTION: The specified degree of protection IP54 can only be achieved with correctly sized cable bushes.

- ▶ (A) Sheath all cables over a length of 70 mm.
- ▶ (B) Shorten the shield to 10 mm.
- ▶ (C) Slide the shield braiding back over the cable sheath.
- ▶ (D) Release the strain relief.
- ▶ Push the cable through the strain relief.
- ▶ Glue EMC shielding foil around the shield.
- ▶ Pull the cable back to the strain relief.
- ▶ Fasten the strain relief.

Attach connector

The required parts and data for preparation are listed in the following table. Connector shell and crimp contacts are included in the accessory set. See also chapter 10 "Accessories and spare parts"

Terminal	Cable cross section [mm ²]	Stripped length [mm]	Crimp contact manufacturer no.	Crimp pliers	Plug manufacturer	Plug type
CN1	0.5 .. 1.5 or 2.5 .. 4.0	5 .. 6	160773-6 341001-6	654174-1	AMP	Positive Lock 1-926 522-1
CN2	0.14 .. 0.6	2.5 .. 3.0	43030-0007	69008-0982	Molex	Micro-Fit 3.0 43025-1200
CN4	0.14 .. 0.6	2.5 .. 3.0	43030-0007	69008-0982	Molex	Micro-Fit 3.0 43025-0600
CN5	0.34 .. 0.6	2.5 .. 3.0	43030-0007	69008-0982	Molex	Micro-Fit 3.0 43645-0200

0098 441 113 191, V1.03, 05.2005

Prepare the cable for connection as follows:

- ▶ Strip the ends of the cable.
- ▶ Attach terminal ends and crimp contacts. Make sure you have the correct crimp contacts and the matching crimping pliers.
- ▶ Slide the terminal end and crimp contacts straight on until they click into the connector.

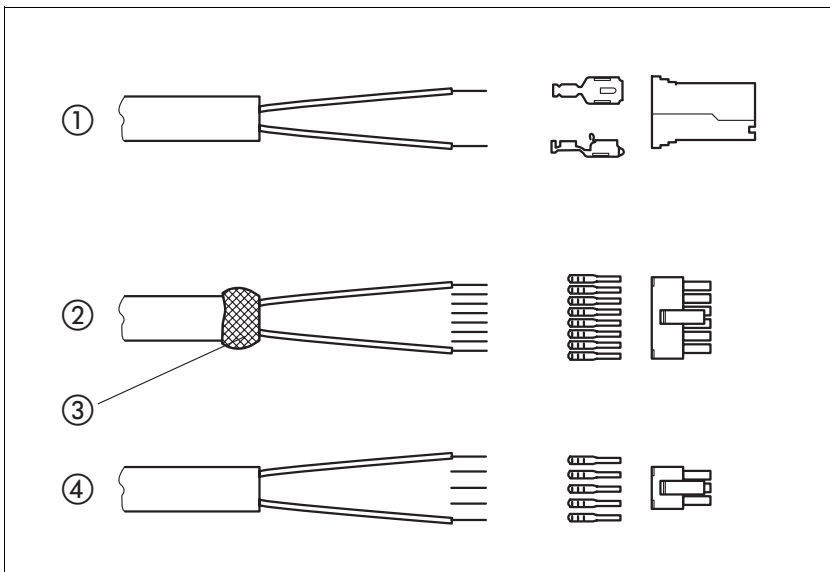

Figure 6.5 Connector, terminal end and crimp contacts

- (1) Supply voltage V_{DC}
- (2) Multifunction interface (pulse input)
- (3) Shielded lead with EMC shield foil
- (4) 24-V signal interface

Installing cable bushing

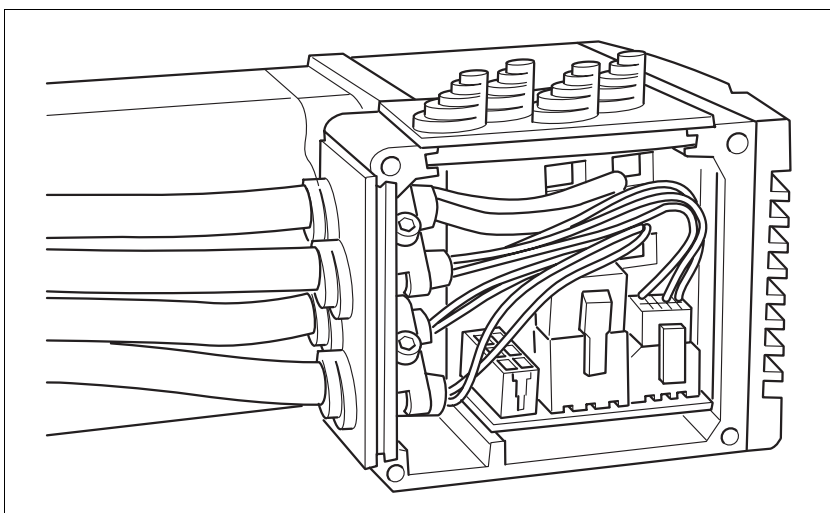

Figure 6.6 Inserting cable bushings

- ▶ Unscrew the side plug housing.
- ▶ If the drive has DIP switches set the DIP switches first, because they are difficult to access when the cables are connected.

For a description of the DIP switch settings see below in the sections that describe the connections.

- ▶ Connect the connector on the prepared cable to the matching socket. All connectors cannot be confused and must click into place when plugged in.

Always hold the connector to remove it (not the cable).

- ▶ Position the cable bushing in one of the two openings provided. The space available in your system will decide the side from which the cable is led out.

CAUTION: Degree of protection IP54 is not assured if the cable bushing is mounted reversed.

- ▶ Close the opening that is not used with a blank cover.

CAUTION: do not use the transport clips.

- ▶ Finally, screw the plug case cover back into place.

If screws are lost use M3x12 only.

6.4.5 Power supply connection ∇ VDC



CAUTION!

Destruction of system components by loss of control over the controller caused by overvoltage at ∇ VDC!

During energy recovery while braking the drive the ∇ VDC supply voltage may increase up to 50V. Components not designed for this voltage may be destroyed or they may malfunction.

- Use a separate power supply unit for the ∇ VDC supply voltage of the drive.
- Do not use the ∇ VDC supply voltage for other consumers (such as limit switches).
- Use only power supply units that will not be damaged by energy recovery.



DANGER!

Electric shock from incorrect power supply unit.

The +24VDC and ∇ VDC supply voltages are connected with many exposed signals in the drive system.

- Use a power supply unit that meets the requirements for PELV (Protective Extra Low Voltage)
- Connect the negative output of the power supply unit to PE.

**CAUTION!****Destruction of contacts.**

The connection for the controller power supply at the drive system does not have a make current limit. If the voltage is switched on by switching contacts, the contacts may be destroyed or welded shut.

- Use a power supply that limits the peak value of the output current to a value permissible for the contact.
- Switch the line input of the power supply instead of the output voltage.

**CAUTION!****Destruction of unit components and loss of control monitoring!**

Excessive currents can be created at the signal connections if the negative connection to the controller supply voltage is interrupted.

- Do not interrupt the negative connection between power supply unit and load with a fuse or switch
- Check for correct connection before switching on.
- Never connect the controller supply voltage or change its wiring while there is supply voltage present.

Cable specifications

- Cross section 2 x 0.75 ... 4.0 mm²

Unshielded cables may be used for the VDC supply voltage. Twisted pair is not required.

- ▶ Use prefabricated cables to minimise the risk of a wiring error.
- ▶ Make sure that the wiring, the cables and the connected interfaces meet the requirements for PELV.

Connecting cable

- ▶ Follow the relevant technical data.
- ▶ See chapter 5.1 "External power supply units" and 5.2 "Ground design".
- ▶ Install fuses for the power supply line in accordance with the selected cross section (note the starting currents).

Pin assignment for printed circuit board plug connector

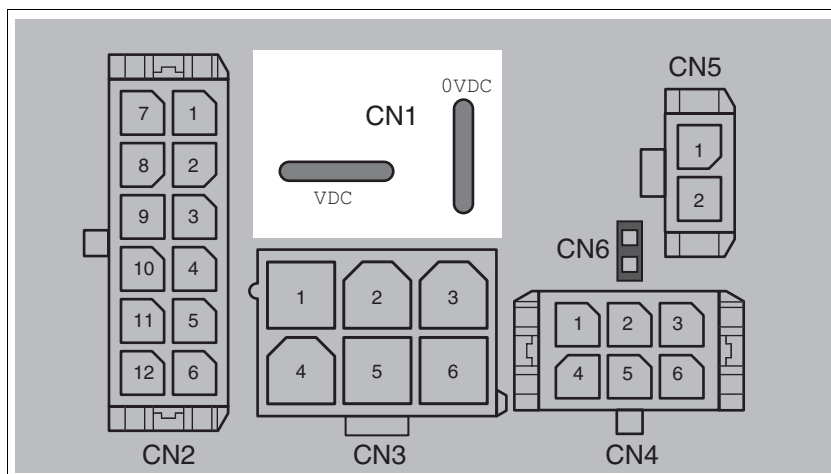

Figure 6.7 Pin assignment for supply voltage

Signal	Meaning	Number ¹⁾
VDC	Supply voltage VDC, 24/36 V _{DC}	1
OVDC	Reference potential	2

1) Information refers to prefabricated wiring

Table 6.2 Pin assignment for supply voltage VDC

You can crimp two leads together to supply multiple drives over one DC bus. Two different crimp contacts are available for different cable cross sections, see 6.4.4 “Connection with cable bushing”.

6.4.6 Connection of multifunction interface

Circuit of the signal inputs The signal input circuits depend on the device version used. the three types PD1, PD2 and PD3 are available.

In drives with PD1 or PD2 the signal inputs and outputs are electrically isolated by optocouplers. The signal inputs operate at 24 V (PD1) or 5 V (PD2) and can be controlled, as described in Figure 6.8.

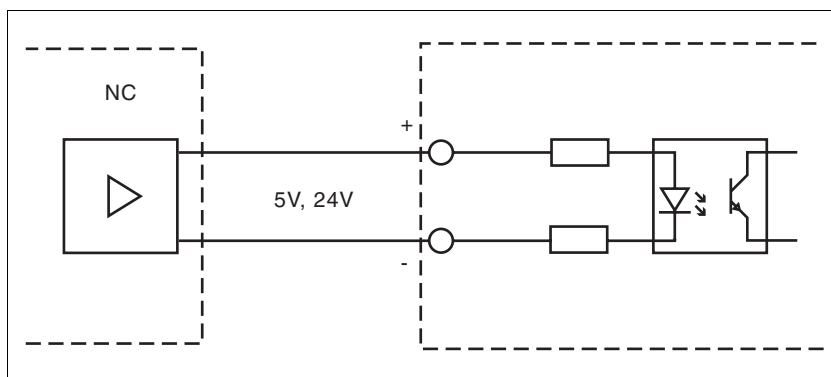

Figure 6.8 Circuits of signal inputs in PD1 and PD2

Compact drives with PD3 operate at the RS422 level and are not electrically isolated, see Figure 6.9.

0098 441 113 191, V1.03, 05.2005

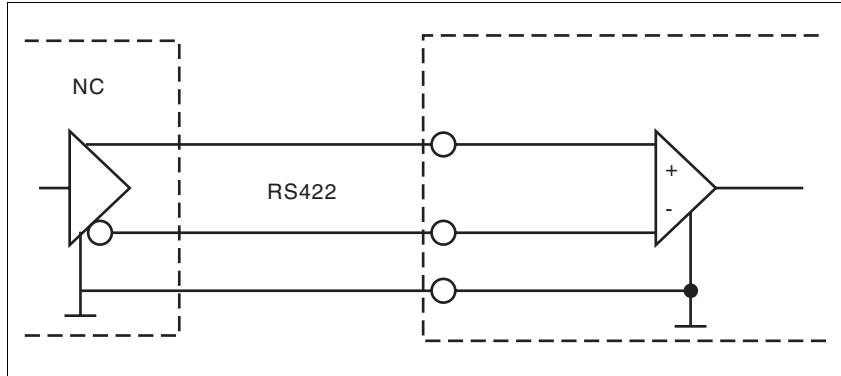

Figure 6.9 Circuits of signal inputs with PD3

- Logical 0
 - 0-level at input "+"
 - 1-level at input "-"
- Logical 1
 - 1-level at input "+"
 - 0-level at input "-"

Open inputs are logical 0.

Circuit of signal outputs

The **ACTIVE** signal output shows that the drive is ready for operation. The signal output is electrically isolated by optocouplers on drives with PD1 or PD2, as shown in Figure 6.10. The signal output switches through if the power amplifier is enabled.

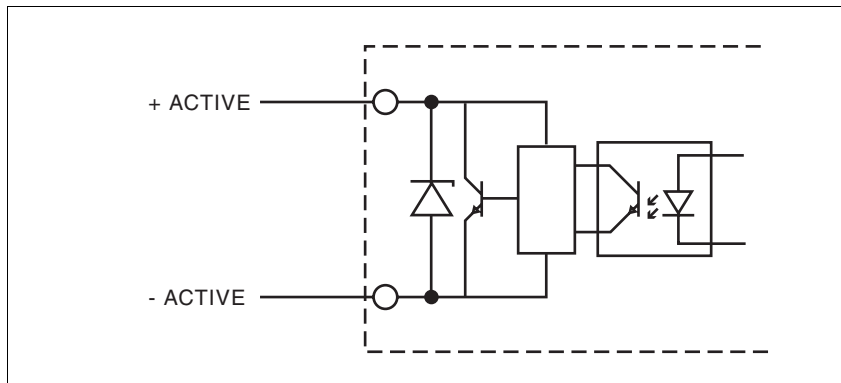

Figure 6.10 Circuits of signal outputs in PD1 and PD2

The signal output on drives with PD3 is an open collector output, which is not electrically isolated. **-ACTIVE** and **0VDC** are connected internally. With the power amplifier enabled the signal output **+ACTIVE** is enabled after **0VDC**.

The signal output **ACTIVE** is short-circuit resistant in all types.

Pin	Signal	Signal value	Meaning
2, 8	ACTIVE	0	Power amplifier is enabled
		high resistance	Power amplifier is disabled

Table 6.3 Enable power amplifier

Cable specifications

- Shielded cable
- Cross section 0.14 ... 0.6 mm²
- Twisted-pair lines
- Earthing of the screen at both ends
- Maximum length: ca. 100 m

The maximum possible length depends on the cross section and the driver circuit used.

- ▶ Use equipotential bonding lines, see page 6-2.
- ▶ Use prefabricated cables to minimise the risk of a wiring error.
- ▶ Make sure that the wiring, the cables and the connected interfaces meet the requirements for PELV.

Pin assignment for printed circuit board plug connector

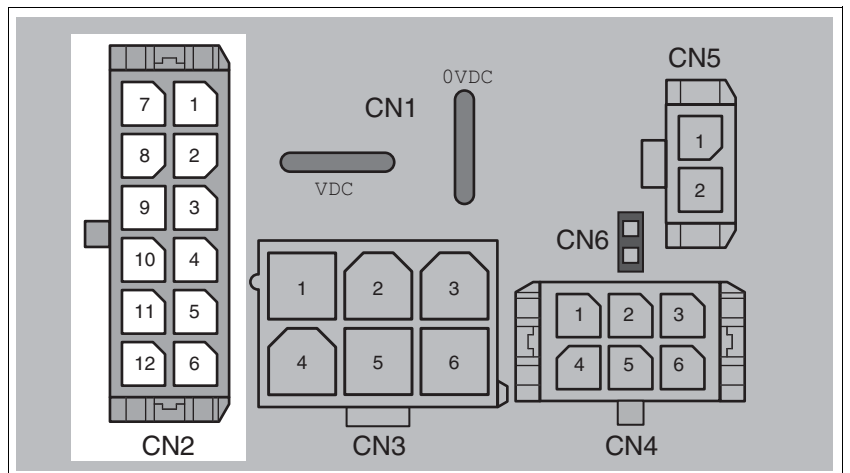

Figure 6.11 Pin assignment for multifunction interface

Pin	Signal	Meaning	Colour ¹⁾	I/O
1	+5V	220Ω resistance against internal +5V	-	
7	0V	Internally connected with CN1 . 0VDC	blue	
2	+ACTIVE	Drive ready	red/blue	O
8	-ACTIVE	Drive ready	grey/pink	O
3	+STEP2_INV or +PWM	Angular resolution or phase current controller	black	I

0098 441 113 191, V1.03, 05.2005

Pin	Signal	Meaning	Colour ¹⁾	I/O
9	-STEP2_INVor -PWM	Angular resolution or phase current controller	purple	I
4	+ENABLEor +GATE	Enable signal	grey	I
10	-ENABLEor -GATE	Enable signal	pink	I
5	+DIRor +A	Direction of rotation "DIR" or A-channel of AB encoder sig- nals	green	I
11	-DIRor -A	Direction of rotation "DIR" or A-channel of AB encoder sig- nals	yellow	I
6	+PULSEor +B	Motor step "PULSE" or B-channel of AB encoder sig- nals	white	I
12	-PULSEor -B	Motor step "PULSE" or B-channel of AB encoder sig- nals	brown	I

1) Information refers to prefabricated wiring

6.4.7 24V signal interface connection

External 24V signal power supply

In the case of drives without internal 24V signal power supply the VDC supply voltage must not be bridged at +24VDC. A separate power supply unit must be used for the 24V signal power supply.



DANGER!

Electric shock from incorrect power supply unit.

The +24VDC and VDC supply voltages are connected with many exposed signals in the drive system.

- Use a power supply unit that meets the requirements for PELV (Protective Extra Low Voltage)
- Connect the negative output of the power supply unit to PE.

Internal 24V signal power supply

A constant 24V signal power supply is available for the sensor power supply on drives with internal 24V signal power supply.

It must not be connected in parallel with the internal 24V signal power supply of a different drive.



Note that for drives with an internal 24V signal power supply different accessories must be used from drives with an external 24V signal power supply.

Cable specifications

- Cross section: 0.2 .. 0.6 mm²
- ▶ Use prefabricated cables to minimise the risk of a wiring error.

0098 441 113 191, V1.03, 05.2005

- ▶ Make sure that the wiring, the cables and the connected interfaces meet the requirements for PELV.

6.4.8 Safety function connection "Safe Standstill"



WARNING!

Danger of injury by incorrect usage!

Incorrect usage may cause a safety hazard by loss of the safety function.

- Observe the requirements for the safety function.

Function Notes and requests to the safety signals SAFE_DISABLE_A and SAFE_DISABLE_B can be found in the chapter 5.3 "Safe Standstill" safety function".

Protected line layout If short circuits and cross connections are possible with the lines for the signals SAFE_DISABLE_A and SAFE_DISABLE_B and this cannot be detected by upstream devices, a protected layout is required.

A protected layout can be achieved as follows:

- Allocation of signals to different cables. Apart from SAFE_DISABLE_A and SAFE_DISABLE_B only wires with voltages corresponding to PELV are permitted to be run on these cables.
- Use of a shielded cable. The earthed shield protects the signals from outside voltages.

If there are multiple wires in the cable, the signals SAFE_DISABLE_A and SAFE_DISABLE_B are kept separate from these wires by the earthed shield.

- Cable specifications*
- Shielded cable corresponding to the requirements for protected layout of wires
 - Minimum cross section of signal wires: 0.34 mm²
 - ▶ Use equipotential bonding lines, see page 6-2.
 - ▶ Use prefabricated cables to minimise the risk of a wiring error.
 - ▶ Make sure that the wiring, the cables and the connected interfaces meet the requirements for PELV.

Pin assignment for printed circuit board plug connector

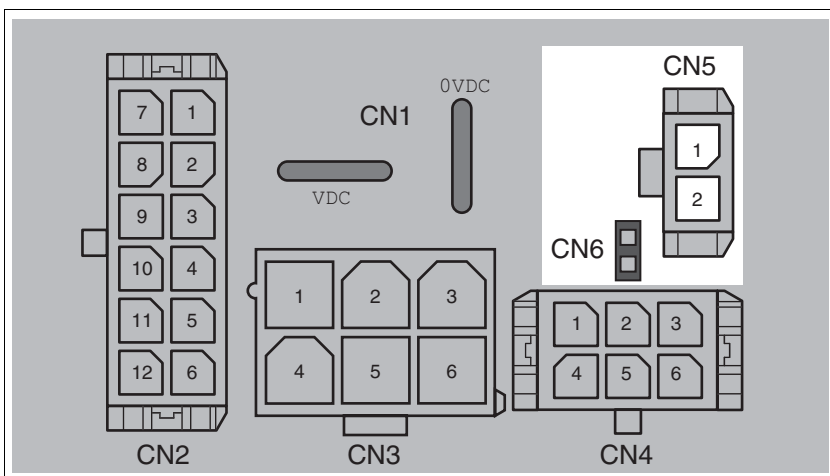

Figure 6.12 Pin assignment of safety function

Pin	Signal	Meaning
1	SAFE_DISABLE_A	Safety function
2	SAFE_DISABLE_B	Safety function

Table 6.4 Pin assignment of safety function

Function CN6 You use the CN6 bridge to specify whether the drive is operated with or without the "Safe Standstill" safety function.

- Bridge connected: "Safe Standstill" safety function disabled
- Bridge disconnected: "Safe Standstill" safety function enabled

The CN6 bridge also offers a simultaneous mechanical lock against CN5. Therefore, CN5 cannot be connected if the CN6 bridge is still connected.

6.5 Checking wiring

Check the following items:

- ▶ Are all cables and connectors safely installed and connected?
- ▶ Are any live cables exposed?
- ▶ Are the control lines connected correctly?
- ▶ Are all seals installed and is degree of protection IP54 specified?
(only with use of the "Safe Standstill" safety function)

7 Commissioning

7.1 General safety instructions



CAUTION!

Hot surfaces can cause burns and damage to system components!

The drive temperature can exceed 100°C in some conditions.

- Avoid contact with the hot drive.
- Do not place combustible or heat-sensitive components in immediate vicinity.
- Follow the actions described for heat dissipation.
- Check the temperature of the drive during the test run.



WARNING!

Unexpected motion may cause injury and damage to the system

When the drive is operated for the first time there is a high risk of unexpected motion because of possible wiring faults or unsuitable parameters.

- If possible, run the first test movement without coupled loads.
- Make sure that a functioning button for EMERGENCY STOP is within reach.
- Also anticipate a movement in the incorrect direction or oscillation of the drive.
- Make sure that the system is free and ready for the motion before starting the function.

**WARNING!****Unexpected responses may cause injury and damage to the system**

The behaviour of the drive system is governed by numerous stored data or settings. Unsuitable settings or data may trigger unexpected movements or reactions to signals and disable monitoring functions.

- Do not operate a drive system with unknown settings or data.
- Check the stored data or settings.
- When commissioning carefully run tests for all operating states and fault cases.
- Check the functions after replacing the product and also after making changes to the settings or data.
- Only start the system if there are no persons or materials in the danger zone and the system can be operated safely.

**WARNING!****Danger of injury and damage to system components by unbraked motor!**

Loss of power or faults that result in switching off the power amplifier mean that the motor is no longer actively braked and may run against a mechanical stop at high speed.

- Check the mechanical conditions.
- If necessary, use an absorbent mechanical stop or a suitable brake.

**WARNING!****Rotating parts may cause injury and damage to the system.**

Rotating parts may cause injuries and may catch clothing or hair. Loose parts or parts that are unbalanced may be thrown clear.

- After installation check all rotating parts (parallel keys, clutch, ..).
- Use a guard as protection against rotating parts.

**WARNING!****Danger of injury from falling parts.**

The motor may move as a result of the reaction torque, tip and fall.

- Fasten the motor securely to prevent it from breaking loose during strong acceleration.

7.2 Preparing for commissioning

The following tests are required before commissioning:

- ▶ Wiring and connection of all cables and system components
- ▶ Limit switch function, if installed

One of the following must be available:

- Fieldbus master (e.g. PLC) or industrial PC
- IcIA Easy commissioning software

7.3 Running commissioning

7.3.1 Testing safety functions

Operation with "Safe Standstill" Carry out the following steps to use the "Safe Standstill" function: Make sure that the sequence is retained.

- Supply voltage switched off.
- ▶ Check that the inputs $\overline{\text{SAFE_DISABLE_A}}$ and $\overline{\text{SAFE_DISABLE_B}}$ are electrically isolated from each other. The two signals must not be electrically connected.
- ▶ Trigger the safety disconnection. $\overline{\text{SAFE_DISABLE_A}}$ and $\overline{\text{SAFE_DISABLE_B}}$ must be disconnected.
- ▶ Switch on the VDC voltage supply.
- ▶ Reset the safety disconnection. $\overline{\text{SAFE_DISABLE_A}}$ and $\overline{\text{SAFE_DISABLE_B}}$ must be switched on simultaneously (skew <1s).
- ▶ Enable the power amplifier.

Input ENABLE/GATE to ENABLE	Input ENABLE/GATE to GATE
Enable the power amplifier with the input signal ENABLE, see chapter 8.2.2 "Input ENABLE"	Power amplifier is automatically enabled

- ◁ The power amplifier switches on. If the power amplifier is not switched on, there is a wiring error.
- ▶ Trigger the safety disconnection. $\overline{\text{SAFE_DISABLE_A}}$ and $\overline{\text{SAFE_DISABLE_B}}$ must be switched off simultaneously (skew <1s).
- ◁ The power amplifier switches off and the output FAULT is set. If the power amplifier is not switched off, there is a wiring error.
- ▶ Check the behaviour of the drive in error states.
- ▶ Record all tests of the safety function in the acceptance record.

Operation without "Safe Standstill" If you do not want to use the safety function:

- ▶ Check whether the bridge CN6 is connected.

7.3.2 Check function of limit switches

You can secure the movement range of the motor with limit switches. The limit switch signals must be monitored by the master controller. When the limit switch is tripped the master controller must interrupt the reference value pulses to the drive.

- ▶ Check the function of the limit switches before operating the drive in the system.

7.3.3 Running test movement



WARNING!

Unexpected movement may cause injury and damage to the system.

- Run the first test movement with no coupled load.
- If the drive is already installed in a system, make sure that unexpected movements will not cause any damage.
- Start the first test movement with low pulse frequency. If the "DIR" signal is disabled, the drive must rotate clockwise.

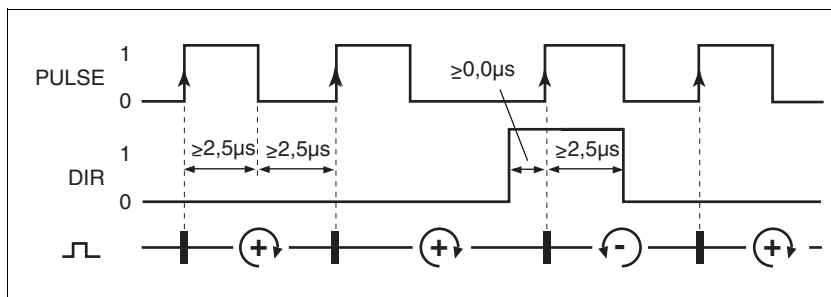

Figure 7.1 Checking motor direction of rotation

If the motor follows the pulse signals, the motor is correctly controlled.

7.3.4 Optimising travel behaviour of the motor

Selecting number of steps

The compact drive operates with a patented soft-step process, in which every input pulse is broken down into many small internal increments. The number of steps should be set as high as possible for optimum synchronism. Ensure that higher frequencies are not fed in at a higher number of steps.

From an input frequency of 100 Hz the compact drive switches from single-step mode to movement mode. This ensures smoother synchronism of the motor.

Calculating and testing cut-off frequencies

The cut-off frequencies for the following operating phases must be set at the NC controller for optimum operation of the compact drive:

- Acceleration phase
- start-stop phase

The cut-off frequencies of a motor depend on the following quantities:

- Motor torque
- External mass moment of inertia

You can use these moments to derive the limit frequencies from the characteristic curves.

Proceed as follows to calculate the cut-off frequencies:

- Calculate the moment of inertia of the system reduced to the axis.

- Calculate the following values based on the characteristic curve graph of the motor and the motor torque:
 - Maximum start-stop frequency
 - Slope of frequency ramp

Frequency for the start-stop phase

The unloaded motor starts and stops at the start-stop frequency. If external moments of inertia affect the motor, you will need to select a lower frequency for the start-stop phase.

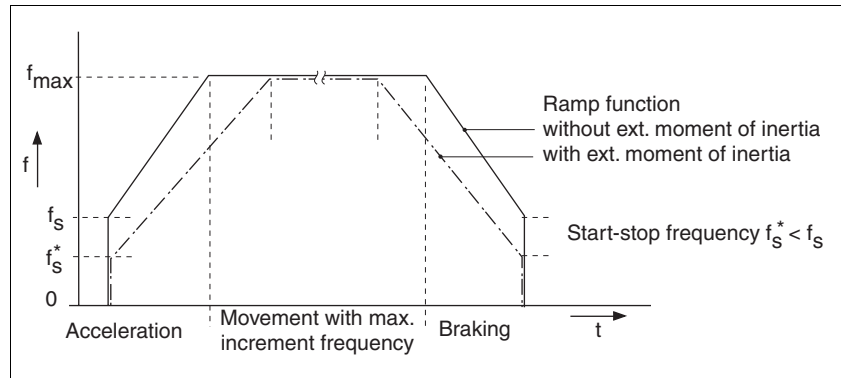

Figure 7.2 Characteristic curves of the linear ramp

Limit the pulse frequency to the start-stop frequency before you change the direction of rotation.

Frequency ramp

In the acceleration and braking range above the start-stop frequency the control frequency must be changed continuously corresponding to the frequency ramp.

The rise of the frequency ramp depends on the external moment of inertia and depends on the motor type.

- ▶ Programme the frequency data into the NC controller or the compact drive.
- ▶ Start the test run under realistic load conditions.

8 Operation

The "Operation" chapter describes the basic functions of the drive.

8.1 Basics

8.1.1 Overview

Drive The "Intelligent Compact Drive" moves the stepper motor as specified by a setpoint input. The setpoint signal is generated by a positioning or NC controller and fed to the multifunction interface as a pulse signal.

The resolution can be adjusted by the number of steps.

Functions Different functions can be controlled via the inputs.

- Enable and disable power amplifier and reset errors
- Block pulse input
- Switch step resolution
- Control motor phase current

Specific functions and states can be queried via the outputs.

- Ready
- Error
- Index pulse (optional)

8.1.2 Overview of motor phase current

The motor phase current of the drive is influenced by several factors.

- Setting of switch S4
- Input signal PWM (S2.2 = OFF)
- Current reduction at standstill (S1.4 = ON)

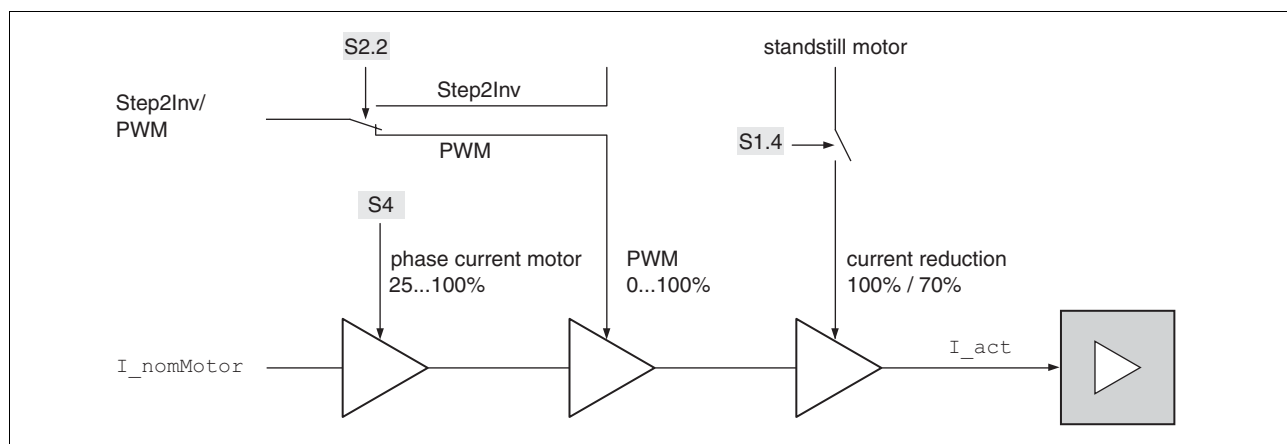

Figure 8.1 Overview of motor phase current

8.2 Functions

8.2.1 Input DIR/A and PULSE/B

The signal inputs DIR/A and PULSE/B are used in combination:

- "PULSE/DIR" interface mode
Pulse direction signals
- "A/B" interface mode
AB encoder signals

The maximum frequency is 200 Hz.

"PULSE/DIR" interface mode

The motor executes an angular step with the leading edge of the PULSE signal. The direction of rotation is controlled by the DIR signal.

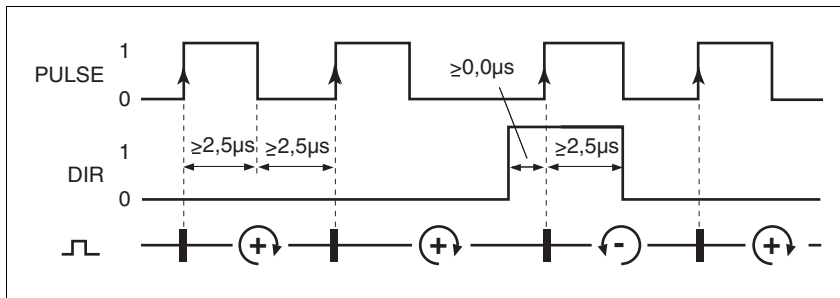

Figure 8.2 Pulse direction signals

Signal	Signal value	Meaning
PULSE	0 -> 1	Angular step
DIR	1	Anti-clockwise rotation
	0 / open	Clockwise rotation

"A/B" interface mode

A/B encoder signals can be fed as a reference value selection via the "A/B" interface mode.

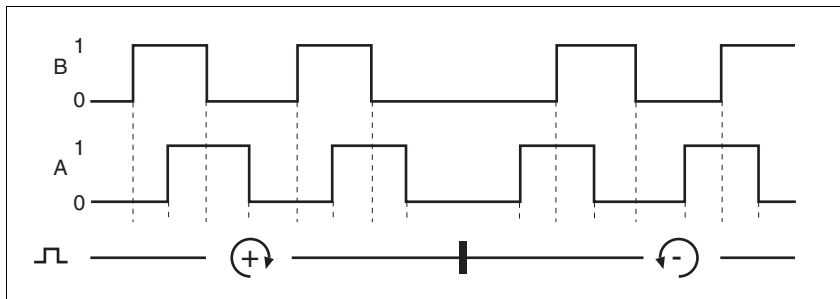

Figure 8.3 AB encoder signals

8.2.2 Input ENABLE

Function

The input ENABLE enables the power amplifier to allow actuation of the motor.

An error message is acknowledged with a negative edge.

Signal value	Meaning
1	Power amplifier is enabled
1 -> 0	Reset error
0 / open	Power amplifier is disabled

If there is no breakdown, the signal output **ACTIVE** displays ready for operation for about 100 ms after the power amplifier is enabled. Then pulses can be fed in.

If the signal **ENABLE** is removed, the power amplifier remains still enabled after approx. 150 ms. This ensures that the holding brake can close. The power amplifier is disabled immediately on drives without a holding brake.

If an error results in the power amplifier being switched off, the signal output **ACTIVE** is disabled and the motor phase current is set to "0".

Operation with "Safe Standstill"

If the drive is operated with the "Safe Standstill" safety function, the input responds edge-controlled and no longer statically.

8.2.3 Input GATE

Function

The input **GATE** blocks the pulses at the reference value input without disabling the operating readiness. In a multi-axis system you can select individual axes with **GATE**.

Signal value	Meaning
1	Pulses are blocked
0 / open	Pulses are released

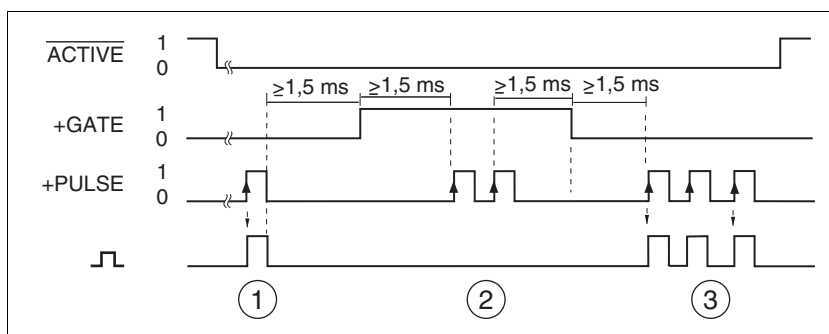

Figure 8.4 Signal sequences during switch-on via GATE

- (1) Motor step
- (2) No motor steps
- (3) Motor steps

There must be no pulse pending for 1.5 ms before and after switching the signal **GATE** to ensure that the drive can follow the pulse preset step by step. If the time period is not met, the LED signals a warning. The warning does not affect the operating readiness of the drive.

Operation with "Safe Standstill"

If the drive is operated with the "Safe Standstill" safety function, the input responds edge-controlled and no longer statically.

8.2.4 Input STEP2_INV

The STEP2INV input can be used if a high positioning precision is required but the output frequency of the master controller is limited.

The number of steps can be increased or reduced by a factor of 10 with the signal input.

The STEP2_INV input inverts the setting of switch S1.1.

The table below shows an example:

Signal value	S1.1	S1.2	S1.3	Motor increment count	Explanation
0 / open	0	0	1	400	Number of motor steps set as with switches S1.1 .. S1.3
1	0	0	1	4000	Setting of switch S1.1 is inverted

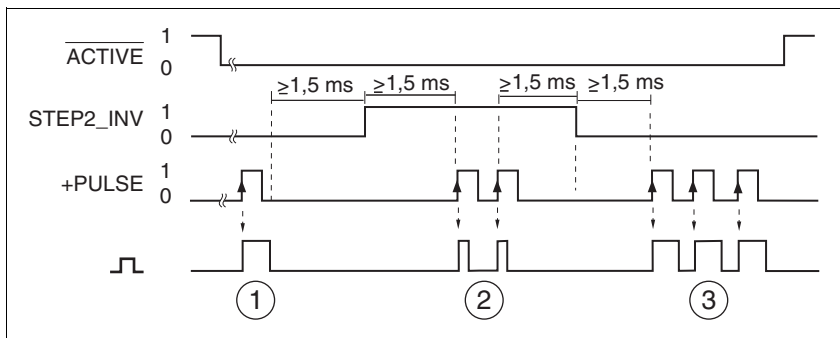

Figure 8.5 Signal sequences as with switching the signal STEP2_INV

- (1) Large motor step
- (2) Motor steps lower by a factor of 10
- (3) Large motor steps

There must be no pulse pending for 1.5 ms before and after switching the signal STEP2_INV to ensure that the drive can follow the pulse pre-set step by step. If the time period is not met, the LED signals a warning. The warning does not affect the operating readiness of the drive.

8.2.5 Input PWM

With the PWM input (**P**ulse**w**idth**m**odulation) the motor phase current (and thus the torque) can be reduced between 0% and 100% of the current that is set at switch S4.

1-level At constant 1-level no motor phase current flows (current zero).

0-level At constant 0-level the motor operates at the specified maximum motor phase current.

Square-wave signal If a square signal is fed, the motor phase current can be set with the pulse-pause ratio. The frequency of the square-wave signal must be between 6 kHz and 25 kHz.

8.2.6 Output ACTIVE

The ACTIVE output shows that the drive is ready for operation.

Signal value	Meaning
1	Power amplifier is enabled
0	Power amplifier is locked

8.2.7 Output FAULT

The FAULT output shows an error status. An error can be reset by locking and enabling the power amplifier (signal ENABLE: 0 -> 1)

Signal value	Meaning
1	Error
0	No error

8.2.8 Output INDEXPULSE

If the drive has the optional internal Hall sensor on the motor shaft, the Hall sensor sends the INDEXPULSE signal once per revolution.

Signal value	Meaning
1	Index pulse
0	No index pulse

9 Diagnostics and troubleshooting

9.1 Error display and troubleshooting

9.1.1 Operation and error display

The motor and the power amplifier are protected against overload and overheating by various monitoring systems.

Temperature monitoring Sensors in the drive measure the temperature of the power amplifier.

If the permissible limit temperature is exceeded, the power amplifier switches off and reports a temperature error.

Stall detection The stall detection checks whether the index pulse is always triggered at the same angular position of the rotating field during the motor movement. If a stepper motor stalls, the motor shaft is displaced in relation to the rotating field by an angle corresponding to one or more complete pole pairs. One pair of poles corresponds to 1/50 of a revolution.

Restrictions:

- The stall detection is initially inactive every time the power amplifier is activated. The detection is automatically enabled as soon as the index pulse is overrun; this occurs after a maximum of one motor revolution. A stall of one or more pole pairs is only detected from this point on.
- If the stepper motor stalls during braking shortly before standstill, this will be only detected when the index pulse is overrun next time, i.e. possibly only on the next movement.
- If the area of travel of the application is less than one complete motor revolution, the stall detection will not operate reliably.
- If the motor shaft is rotated by external forces during standstill, the stall detection will not necessarily detect this. If the motor shaft remains at the standstill exactly at the index pulse, a distinction between oscillations and true rotary movement cannot be made. The stall is detected at the next movement unless the motor shaft was rotated exactly one full revolution.

Error message via the 24-V signal interface An error is sent to a master controller via the signal output "FAULT/IND-EXPULSE" (pin 3) of the 24V signal interface. The power amplifier is locked simultaneously and the "ACTIVE" signal switches to LOW.

Status display The LED shows error messages and warnings. It shows the operating status in coded form.

Status display	Meaning
	<ul style="list-style-type: none"> • Start-up • Undervoltage, "Safe Standstill" • Power amplifier inactive • Power amplifier active • Warning • Error • internal error

9.1.2 Reset error message

When the malfunction is corrected and the DIP switch 2.1 is set to "OFF", the error message can be acknowledged by resetting the output signal "ENABLE".

If DIP switch 2.1 is set to "ON", the output signal "GATE" is active. An error message can then only be acknowledged by switching off the power supply.

9.1.3 Error classes and error response

Error response The product triggers an error response in the event of a fault. Depending upon the gravity of the fault, the unit responds in accordance with one of the following error classes:

Error class	Response	Description
0	Warning	Message only, no interruption of movement mode.
3	Fatal error	Power amplifier and controller switch off immediately, without stopping the motor first.
4	Uncontrolled operation	Power amplifier and controller switch off immediately, without stopping the motor first. Error response can only be reset by switching the unit off.

9.1.4 Causes of errors and troubleshooting

Errors trigger an error response in the compact drive.

Signalling of an error by the compact drive:

- Setting the signal output "FAULT"
- Internal LED flashing

Error	Error class	Cause of error	Troubleshooting
LED off	–	No power	Check power supply and fuses

Error	Error class	Cause of error	Troubleshooting
Warning	0	Timing of GATE or STEP2_INV not retained	Check time response of signals at the multifunction interface
Undervoltage	3	Supply voltage below threshold value for switching off the drive	Check voltage, check connections
Stall detection	3	Drive is blocked or stalled Movement frequency too high Acceleration too high	Reduce load torque or motor torque; check settings for motor phase current; reduce travel frequency reduce acceleration
Maximum motor speed	3	Maximum motor speed exceeded	Reduce pulse frequency
Overvoltage	3	Overvoltage, feedback, loss of synchronism at high speed	See chapter 5.1 "External power supply units"
Overtemperature	3	Power amplifier or motor overheated Ambient temperature too high Inadequate heat dissipation	Improve heat dissipation via the motor flange or reduce motor phase current
Timing error	3	Timing of "PULSE" nor retained Interference pulses present	Reduce pulse frequency Check EMC measures Check earth concept
Watchdog	4	Internal system error	Switch drive off and on Replace drive
Inputs for SAFE_DISABLE have 0-level	3	"Safe Standstill" has been triggered	Check guard door, wiring
Inputs for SAFE_DISABLE different	4	Interruption of the signal wiring	Signal cable/connection to be checked, check signal encoder or change

Table 9.1 Troubleshooting

9.1.5 Troubleshooting malfunctions in movement mode

Malfunction	Cause of malfunction	Correction of cause
Motor does not rotate and has no holding torque	Signal input "PWM" = HIGH	Disable PWM
	Signal input "ENABLE" = LOW	Enable power amplifier
Motor does not rotate but has holding torque	Signal input "GATE" = HIGH	Disable "GATE" signal to enable pulses.
	Pulse frequency	Check timing and signal voltage level of "PULSE/DIR" input signals
Motor rotates irregularly	Pulse frequency	Check timing and signal voltage level of "PULSE/DIR" input signals
	Overload	Reduce load torque
	Motor defective	Replace compact drive
Motor rotates in the wrong direction	+DIR/-DIR incorrectly connected AB signals swapped	Check signals, connect correctly
Motor torque too low	Motor phase current incorrectly set	Set motor phase current (increase)

Table 9.2 Malfunctions in movement mode

10 Accessories and spare parts

10.1 Documentation

Designation	Ordering number
IclA Ixx CD-ROM multilingual	0098 441 113 207
IclA IDS device manual, DE	0098 441 113 190
IclA IDS device manual, EN	0098 441 113 191

10.2 Accessories

Designation	Ordering number
Ixx Installation Set	0062 501 521 001
Ixx cable bushings (2 units)	0062 501 520 002
Ixx cable bushings (10 units)	0062 501 520 001
IDx cable (power, P/R), 3m	0062 501 464 030
IDx cable (power, P/R), 5m	0062 501 464 050
IDx cable (power, P/R), 10m	0062 501 464 100
IDx cable (power, P/R), 15m	0062 501 464 150
IDx cable (power, P/R), 20m	0062 501 464 200

The tools required for fabrication must be ordered directly from the manufacturer.

- Crimping pliers for CN1: AMP 654174-1
- Crimping pliers for CN2 and CN4: Molex 69008-0982
- Crimping pliers for CN3: Molex 69008-0724
- Extraction tool for CN2 and CN4: Molex 11-03-0043
- Extraction tool for CN3: Molex 11-03-0044

An RS232/USB to RS485 converter is required for service and to upgrade the operating system.

- NuDAM RS232-RS485 converter: Acceed ND-6520
- NuDAM USB-RS485 converter: Acceed ND-6530

11 Service, maintenance and disposal



CAUTION!

Destruction of unit components and loss of control monitoring!

Excessive currents can be created at the signal connections if the negative connection to the controller supply voltage is interrupted.

- Do not interrupt the negative connection between power supply unit and load with a fuse or switch
- Check for correct connection before switching on.
- Never connect the controller supply voltage or change its wiring while there is supply voltage present.



You cannot carry out repairs yourself. The repair should only be carried out by a certified customer service organisation. No warranty or liability is accepted for repairs made by the customer.

11.1 Service address

If you cannot resolve the fault yourself please contact your appointed sales partner. Have the following details available:

- Type, identification number and serial number of the product (type plate)
- Type of fault (possibly with fault number)
- Previous and concurrent conditions
- Your own ideas regarding the cause of the fault

Include this information if you return the product for inspection or repair.



If you have any questions please contact your local dealer. Your dealer will be happy to give you the name of a customer service outlet in your area.

11.2 Maintenance

The unit is maintenance free

11.2.1 Operational duration of safety function

The operating life for the Safe Standstill function is designed to be 20 years. After this period correct function is no longer ensured. The expiry date of the unit is determined by adding 20 years to the DOM shown on the type plate.

- ▶ This date must be included in the system maintenance schedule.

Example The name plate on the unit includes the DOM in the DD.MM.YY format, e.g. 31.12.06. (31 December 2006). This means that the safety function is guaranteed until 31 December 2026 (06 + 20 = 26).

11.3 Replacing units



WARNING!

Unexpected responses may cause injury and damage to the system

The behaviour of the drive system is governed by numerous stored data or settings. Unsuitable settings or data may trigger unexpected movements or reactions to signals and disable monitoring functions.

- Do not operate a drive system with unknown settings or data.
- Check the stored data or settings.
- When commissioning carefully run tests for all operating states and fault cases.
- Check the functions after replacing the product and also after making changes to the settings or data.
- Only start the system if there are no persons or materials in the danger zone and the system can be operated safely.

Observe the following procedure when changing the units.

- ▶ Note all switch settings.
- ▶ Switch off all power supplies. Make sure that power is no longer connected (safety instructions).
- ▶ Label all connections and remove the product.
- ▶ Note the identification number and the serial number from the product type plate for later identification.
- ▶ Install the new product as specified in 6 "Installation"
- ▶ Carry out commissioning in accordance with chapter 7 "Commissioning".

11.4 Shipping, storage, disposal

Removal Removal procedure:

- ▶ Switch off the power supply.
- ▶ Disconnect the power supply.
- ▶ Pull out all plugs.
- ▶ Remove the compact drive from the system.

Shipping The product must be protected against shocks during transport. Use the original packaging for this purpose.

Storage Store the product only under the specified, approved environmental conditions for room temperature and humidity. Protect the product against dust and dirt.

Disposal The product consists of various materials that can be recycled and must be disposed of separately. Dispose of the product in accordance with local regulations

12 Glossary

12.1 Terms and Abbreviations

<i>AC</i>	Alternating Current
<i>ASCII</i>	American Standard Code for Information Interchange; Standard for coding text characters
<i>Stall detection</i>	The stall detection monitors that the optional index pulse is always correctly triggered at the same angular setting of the motor axis. Only for stepper motor drives with index pulse.
<i>CAN</i>	(C ontroller A rea N etwork), standardized open Fieldbus over which the drives and other devices from different manufacturers communicate with one another.
<i>DC</i>	Direct current
<i>Default value</i>	Factory settings.
<i>DIP switch</i>	Small switches positioned side by side. They must be set during installation.
<i>DOM</i>	(D ate o f m anufacturing), the type plate of the device shows the date of manufacture in the format DD.MM.YY, e.g. 31.12.06 (31. December 2006).
<i>Direction of rotation</i>	Rotation of the motor shaft in a positive or negative direction of rotation. A positive direction of rotation is defined as the motor shaft rotating clockwise as the observer faces the end of the protruding shaft.
<i>I/O</i>	Inputs/Outputs
<i>E</i>	Encoder
<i>EC motor</i>	Electronically commutated motor
<i>EC</i>	European Community
<i>EMC</i>	Electromagnetic compatibility
<i>Encoder</i>	Sensor for recording the angular position of a rotating element. The encoder is mounted on the motor and signals the angular position of the rotor.
<i>Limit switch</i>	Switch that signals an overrun of the permissible travel range.
<i>Power amplifier</i>	A device that generates current for controlling the motor in accordance with the positioning signals from the controller.
<i>EU</i>	European Union
<i>Error class</i>	Classification of possible operating faults of the drive system that result in an error status.
<i>High/open</i>	Signal status of an input or output signal; in the idle state the signal voltage is high, high level.
<i>Inc</i>	Increment
<i>Index pulse</i>	Encoder signal for referencing the rotor position in the motor. The encoder sends one index pulse per revolution.
<i>LED</i>	Light-Emitting Diode

<i>Low/open</i>	Signal status of an input or output signal; in the idle state signal voltage is low (low level).
<i>M</i>	Motor
<i>Torque ramp</i>	Brakes the motor with the maximum possible deceleration, which is only limited by the maximum permissible current. The higher the permissible braking current, the stronger the deceleration. Because energy is taken up depending on the coupled load, the voltage may increase to excessive values. In this case the maximum permissible current must be reduced.
<i>Motor phase current</i>	In a stepper motor the available torque is specified by the motor phase current. The higher the motor phase current the higher the torque.
<i>Node-Guarding</i>	Monitoring function with slave at an interface for cyclic communication.
<i>Parameter</i>	Device functions and values that can be set and called by the user.
<i>PC</i>	Personal Computer
<i>per</i>	Designation of whether the value of the parameter is persistent, i.e. after switching off the unit it is retained in the memory. When changing a value via commissioning software or fieldbus, the user must explicitly store the value change in the persistent memory.
<i>Profibus</i>	Standardised open fieldbus compliant with EN 50254-2 over which drives and other devices from different manufacturers communicate with one another.
<i>PWM</i>	Pulse Width Modulation
<i>Quick Stop</i>	Quick stop, function used to provide quick braking of the motor via a command or in the event of a fault.
<i>RS485</i>	Fieldbus interface compliant with EIA-485, which enables serial data transmission with multiple devices.
<i>SM</i>	Stepper motor
<i>PLC</i>	Programmable Logic Controller
<i>Watchdog</i>	Equipment that monitors cyclic basic functions in the drive system. Power amplifier and outputs are switched off in the event of error.

12.2 Product name

<i>IcIA IDS</i>	Intelligent Compact Drive with pulse/direction interface and stepper motor
<i>IcIA IFA</i>	Intelligent Compact Drive with fieldbus interface and servomotor
<i>IcIA IFE</i>	Intelligent Compact Drive with fieldbus interface and EC motor
<i>IcIA IFS</i>	Intelligent Compact Drive with fieldbus interface and stepper motor

13 Index

Numerics

- 24V signal interface
 - connecting 6-18
 - wiring specifications 6-18

A

- Abbreviations 12-1
- Accessories 10-1

C

- Cable specifications
 - power supply 6-14
- Category 0 stop 5-3
- Category 1 stop 5-3
- Causes of error 9-2
- CE mark 1-5
- Commissioning 7-1
 - checking safety functions 7-4
 - preparation 7-3
 - running 7-3
- Cut-off frequency 7-5

D

- Danger classes 2-2
- Declaration of conformity 1-7
- Diagnostics 9-1
- Directives 1-5
- Disposal 11-1, 11-3

E

- Electrical installation 6-4
- Environmental conditions 3-1
- Equipotential bonding conductors 5-3, 6-2
- Error class 9-2
- Error classes 9-2
- Error response 9-2
 - meaning 9-2
- External power supply unit 5-1

F

- Frequency ramp 7-6
- Function
 - Profibus fieldbus interface 6-19
- Functions 8-2

G

- Glossary 12-1

I

Installation

- electrical 6-4
- mechanical 6-2

Installation, electrical

- connecting 24V signal interface 6-18
- Connecting supply voltage 6-13
- preparing cables 6-10

Intended use 2-1

M

Maintenance 11-1

Mechanical installation 6-2

Monitoring functions 2-3

N

Number of steps 7-5

O

Operation 8-1

Optimising travel behaviour 7-5

Overview 8-1

P

Power supply

- cable specifications 6-14

Preparing cables 6-10

Product name 12-2

Profibus fieldbus interface
function 6-19**Q**

Qualifications, personnel 2-1

R

Reset error message 9-2

S

Safe Standstill 5-3

- application examples 5-5
- definition 5-3
- short description 5-3

Safe Stop

- safety information 5-4

Safety function 5-3

Safety functions 2-2, 3-2, 4-1

Service 11-1

Service address 11-1

Shipping 11-3

Standards 1-5

start-stop phase 7-6

Storage 11-3

Supply voltage
connecting 6-13

T

Technical data 3-1
Temperature monitoring 9-1
Terms 12-1
Test movement 7-5
Testing safety functions 7-4
Troubleshooting 9-1, 9-2
Troubleshooting malfunctions in movement mode 9-3

U

Unit overview 1-2

W

Wiring specifications
24V signal interface 6-18

